



# 14th World Flower Show

## LAND OF CONTRASTS



A U S T R A L I A

2024 - 2027

# COMPETITION SCHEDULE

16th - 23rd March 2027

Sydney Olympic Park, Sydney

# TABLE OF CONTENTS

03	Welcome from WAFA Australia Management Committee President
03	Welcome from Competition Show Chairperson
04	Meet the WAFA Board
05-06	Competitors Timetable
07	Important Dates and Contacts
08-09	Competition Information
10	International World Flower Show Rules
10	Cancellation Policy
11	Junior Class Rules
12-13	Staging Regulations
14	General Information
15-16	Plant Material Information
17	Sydney Flower Market Traders
18-19	Prohibited Plant Materials List
20	Venue map
21	Sydney Flower Market map
22	Class Distribution Floor Plan
23-34	Land of Contrasts - Class No's 1 - 24
35	Special Awards Sponsors
36	14 <sup>th</sup> WAFA World Flower Show Sponsors

Sydney Harbour Bridge  
and  
the Opera House



Uluru (Ayers Rock)  
and  
Spinifex Grass

# WELCOME

*President WAFA Australia Management Committee*

## MADHU SHAH

It is with great joy and anticipation I welcome you all to Australia for the 14th World Association of Floral Artists (WAFA) World Flower Show “Land of Contrasts”, proudly hosted by the Australian Floral Art Association (AFAA) and the WAFA Australia Management Committee in March 2027.

Australia is a land where nature paints with bold strokes. Where deserts meet oceans, ancient landscapes embrace modern cities, and diverse cultures live in harmony. This setting provides the perfect backdrop for a world-class celebration of floral artistry.

We invite you to immerse yourself in a unique experience, to compete, inspire, and to be inspired. Our program promises spectacular floral exhibitions, spirited competitions, educational demonstrations, and moments of global friendships that will stay with you for a lifetime.

The festivities will include a gala dinner and a floral extravaganza, where we will come together to celebrate the universal language of flowers, surrounded by the warmth of new and old friendships.

Let us make the 14th World Flower Show “Land of Contrasts” a true celebration of creativity, beauty, and unity. We cannot wait to welcome you to our beautiful country.

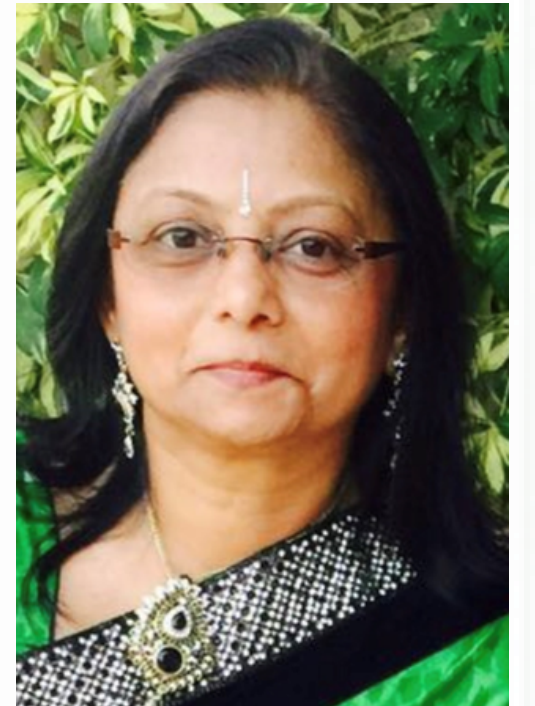

## CECILY ROGERS OAM\*

*Competition Show Chairperson*

*WAFA Australia Management Committee*



It is my pleasure to extend a warm welcome and invite you to embark on an inspiring journey with us at the 14th World Association of Floral Artists (WAFA) World Flower Show “Land of Contrasts”. The venue, Sydney Olympic Park is an iconic venue, renowned as the home of the 2000 Olympic Games, and is one of Australia’s most expansive event spaces.

We are delighted to host a vibrant program of daily stage demonstrations featuring both national and international talent, alongside an array of engaging workshops designed to enrich your floral artistry.

The competition schedule highlights a wide range of themes, drawing inspiration from Australia’s breathtaking landscapes. From the vast Outback Deserts, lush Daintree Rainforest to the dazzling Coral Reefs.

Australian National and International designers, Bart Hassam, Mark Pampling, David Berger, Clement Lee, and Catherine Meads will present a captivating “Floral Extravaganza,” an evening dedicated to creative floral design. They will also lead workshops offering sessions which will be exciting and educational.

So please come on down and experience the magic of “Down Under” and join us in Sydney for an unforgettable celebration of floral art.

Your presence will help shape this event into a truly memorable and successful occasion.

\* OAM = Order of Australia Medal in recognition of services to horticulture and floral art

# MEET THE WORLD ASSOCIATION OF FLORAL ARTISTS LTD BOARD

2024 - 2027



**Kitty Gallagher**  
**President**  
***Ireland***



**Leigh Greenstreet,**  
**Secretary**  
***New Zealand***



**Beverly Hargraft,**  
**Finance**  
***Canada***



**Madhu Shah**  
**Committee Member**  
***Australia***



**Priya Shah**  
**Committee Member**  
***Kenya***

# COMPETITORS TIME TABLE

## Tuesday 16 March 2027

NOTE: The Southee Pavilion is located in Hall 5 of the Flower & Garden Pavilion - Competition Venue. Refer Map Page 20

TIME	SESSION	LOCATION
3.00pm - 5.00pm	World Flower Show Registration for competitors opens	Hospitality Room, Southee Pavilion

## Wednesday 17 March 2027

TIME	SESSION	LOCATION
6.00am - 9.00am	Sydney Flower Market open to the Public	Enter from Marlborough Road, Sydney Flower Market - Shed F Refer to the Map on Page 21.
9.00am - 6.00pm	World Flower Show Registration	Hospitality Room, Southee Pavilion
12.30pm - 2.30pm	Competitors may drop their materials off	Southee Pavilion
4.00pm - 6.00pm	Staging of Mail-in Class No's 5, 11 & 12 and Pre-done Class No's 7, 8, 9, 13 & 14	Southee Pavilion
6.15pm - 7.15pm	Judging of Class No's 5, 7, 8, 9, 11, 12, 13 & 14	Southee Pavilion

## Thursday 18 March 2027

TIME	SESSION	LOCATION
6.00am - 12.00pm	Staging of Competitive Class No's 1, 2, 3, 4, 6, 10, 15, 16, 17, 18, 19 & 20	Southee Pavilion
1.00pm - 5.00pm	Judging of Competitive Classes	Southee Pavilion
7.00pm - 9.00pm	Opening Ceremony & Awards Event (full registrants ONLY) Cocktail Evening	Southee Pavilion

## Friday 19 March 2027

8.00am - 9.00am	Competitors & Judges session for all classes	Southee Pavilion
-----------------	--	------------------

# COMPETITORS TIME TABLE

**Friday 19 March 2027**

NOTE: The Southee Pavilion is located in Hall 5 of the Flower & Garden Pavilion - Competition Venue. Refer Map Page 20

TIME	SESSION	LOCATION
9.00am	Assemble for Imposè Class No 21	Southee Pavilion
9.30am - 12.30pm	Start Imposè Class No 21	Southee Pavilion
1.00pm - 2.00pm	Judging Imposè Class No 21	Southee Pavilion

---

**Saturday 20 March 2027**

TIME	SESSION	LOCATION
9.00am	Assemble for Imposè Class No 22	Southee Pavilion
9.30am - 12.30pm	Start Imposè Class No 22	Southee Pavilion
1.00pm - 2.00pm	Judging Imposè Class No 22	Southee Pavilion

---

**Sunday 21 March 2027**

TIME	SESSION	LOCATION
9.00am	Assemble for Imposè Class No 23	Southee Pavilion
9.30am - 12.30pm	Start Imposè Class No 23	Southee Pavilion
1.00pm - 2.00pm	Judging of Imposè Class No 23	Southee Pavilion

---

**Monday 22 March 2027**

TIME	SESSION	LOCATION
9.00am	Assemble for Imposè Class No 24	Southee Pavilion
9.30am - 12.30pm	Start Imposè Class No 24	Southee Pavilion
1.00pm - 2.00pm	Judging of Imposè Class No 24	Southee Pavilion
7.00pm - 8.00pm	Dismantle Exhibits & Close Show	Southee Pavilion

# IMPORTANT DATES

<b>SUNDAY 1<sup>st</sup> MARCH 2026</b>	Entries Open
<b>FRIDAY 31<sup>st</sup> JULY 2026</b>	Last date for receipt of registration & competition entries.
<b>MONDAY 24<sup>th</sup> AUGUST 2026</b>	Entries to be confirmed to the competitor.
<b>WEDNESDAY 30<sup>th</sup> SEPTEMBER 2026</b>	Last date for competitors to confirm acceptance of their allocated Class.
<b>MONDAY 1<sup>st</sup> FEBRUARY 2027</b>	<p>Mail-in Class exhibits sent by courier or post are to be <b>received</b> by 1<sup>st</sup> February 2027. Send these to:            Madhu Shah, 8 Amaroo Park Drive,            Annangrove NSW 2156 Australia            Please clearly mark your parcel/exhibit with your name &amp; address.</p> <p><b>Ideally please have your pre-made exhibit delivered for staging on 17th March 2027 by an attending registered delegate.</b></p> <p><b>NOTE:</b> International competitors do not use any fresh plant material, nuts or seeds in your pre-made designs as these will be confiscated by Australian Customs &amp; Quarantine. These rules are strictly enforced.</p>

# IMPORTANT CONTACTS

<b>ALL REGISTRATION &amp; COMPETITION ENTRY FORMS</b>	<p>Wafa Australia Finance Officer            Barbara Griffiths            via the website <a href="http://www.wafaaustralia.com">www.wafaaustralia.com</a>            and/or email: <a href="mailto:wafa2027register@gmail.com">wafa2027register@gmail.com</a></p>
<b>COMPETITION ENQUIRIES</b>	<p>Wafa Australia President            Madhu Shah  <a href="mailto:madhushah999@hotmail.com">madhushah999@hotmail.com</a></p>
<b>GENERAL ENQUIRIES</b>	<p>Wafa Australia Secretary            Helen Mitchell  <a href="mailto:wafaaustralia@outlook.com">wafaaustralia@outlook.com</a></p>

# **COMPETITION INFORMATION**

## **REGISTRATION AND RULES**

- Registration opens **1st March 2026**.
- Registration closes **31st July 2026**.
- Registration is open to all members of a floral art society/national association represented in the World Association Floral Artists and is subject to confirmation and receipt of payment.
- Competitive classes are open to individual exhibitors who are members of a floral art society or national association represented in Wafa.
- The registration, workshop and competition entry forms are available online at [www.wafaaustralia.com](http://www.wafaaustralia.com) in the downloadable **Registration Details brochure**.
- Only **ONE** entry per competitor will be accepted.
- If entering a class where 2 people can stage the exhibit, both people **MUST** register and note who they are staging with on the registration form.
- Competitors must indicate their 1st, 2nd and 3rd class choices on **FORM B**.
- All exhibits will be staged in artificial lighting.
- Registration and/or competition and/or workshop fees must be paid at the time of registration via direct bank deposit or online via the Credit Card link in Australian Dollars.
- All delegates entering the competition or booking a workshop must register. This excludes competitors sending mail-in entries for Class No's 5, 11 & 12.
- **Please return your payment advice and all forms to Barbara Griffiths: [wafa2027register@gmail.com](mailto:wafa2027register@gmail.com).**
- Please type or print clearly to avoid errors and retain a copy of all forms for your records.
- Registrants will be notified of competition class allocation, workshop and event tickets by **31st August 2026**.
- Reconfirmation of competition entry is required by email no later than **30<sup>th</sup> September 2026**.
- Only paid registrants will be given access to events.

## FEES

- The registration fee of \$400 is payable by all competitors and delegates entering competition class No's 1, 2, 3, 4, 6, 7, 8, 9, 10, 13, 14, 15, 16, 17, 18, 19, 20, 21, 22, 23 or 24 and by all participants enrolling in workshops.
- Imposed Class No's 21, 22, 23 & 24: A competition fee of AUD \$150.00 per class applies.
- Mail-in Class No. 5: A competition fee of AUD \$50.00 applies. No Registration fee is required.
- Mail-in Junior Class No's 11 & 12: A competition fee of AUD \$25.00 per class applies. No Registration fee is required.
- Bank transfer fees are to be payable by the delegate.

## VENUE & ENTRY

- All competitors should enter the Showground via the Main Entry gate, located close to the Olympic Park Train Station. Refer to the map on page 20.
- Competitors are able to deliver their plant material and sundry items to the venue on Wednesday 17<sup>th</sup> March 2027. These can be placed where the finished designs will be displayed.
- All competition classes will be held in the Southee Pavilion in Hall 5 of the Flower and Garden Pavilion within the grounds of the Sydney Showground, Sydney Olympic Park. Enter through the curved glass doors.
- Workshops will be held in the Sommerville & Pearson Rooms on Level One in the Woolworths Fresh Food Dome.
- A High Visibility vest and enclosed shoes **must be worn** on site during setup and staging on Tuesday 16<sup>th</sup>, Wednesday 17<sup>th</sup> and Thursday 18<sup>th</sup> March. Competitors will be provided with a high-visibility vest on their first entry into the Showground at the Main Entry Gate.

## JUDGING & AWARDS

- Judging for the mail-in and pre-done classes will take place from 6.15pm on Wednesday 17 March 2027.
- Judging for all other competition classes will take place from 1pm Thursday 18 March 2027.
- In addition to Special Awards, prizes will be presented to First, Second and Third places in each class, with Highly Commended and Commended where appropriate.
- The Judges decisions are final.
- The judges will be available for informal discussion between 8.00am - 9.00am on Friday 19th March 2027.

# INTERNATIONAL WORLD FLOWER SHOW RULES

1. An exhibit is made of plant material, with or without accessories, within a space specified in the Show Schedule.
2. Plant material must predominate over all other components of the exhibit.
3. The use of artificial plant material is forbidden.
4. Fresh plant material must be in water or water-retaining material unless such material remains turgid throughout the event.
5. Painted and/or artificially coloured plant material may be used.
6. Pre-prepared work must be no more than 40% of the completed design and must not predominate in the exhibit.

## CANCELLATION POLICY

### **Before 1st December 2026:**

Payments made will be refunded via bank transfer (any applicable bank charges are the responsibility of the delegate).

### **Between 1st January and 1st February 2027:**

Refunds will only be issued if your place is taken by another delegate.

### **After 1st February 2027:**

No refunds are available

In the event of non-attendance at the World Flower Show:

No refunds are available.

# JUNIOR CLASS RULES

- Exhibit must be solely the work of the exhibitor.
- A label with the exhibitor's name, date of birth and address must be included with the design.
- An exhibit is made of plant material, with or without accessories, within the space allocated.
- Plant material must predominate over all other components in the exhibit.
- Fresh plant material, if used, must be in water or water retaining material unless the plant material will remain in good condition for the duration of the show.
- Painted/and or artificially coloured plant material may be used.
- The use of artificial plant material is forbidden.
- Exhibits in Class No's 11 & 12 are to be mailed in or delivered ready assembled for staging by the Show committee.
- Juniors are not permitted in the Pavilion during the staging times.
- Registration fee is not required.
- Competition Entrance Fee payable is AUD \$25.00
- Class No. 11 is open to juniors aged 7 - 11 years old.
- Class No. 12 is open to juniors aged 12 - 16 years old.

## **ALL REGISTRATION FORMS**

Wafa Australia Finance Officer  
Barbara Griffiths  
via the website [www.wafaaustralia.com](http://www.wafaaustralia.com)  
and/or email:  
[wafa2027register@gmail.com](mailto:wafa2027register@gmail.com)

## **COMPETITION ENQUIRIES**

Wafa Australia President  
Madhu Shah  
[madhushah999@hotmail.com](mailto:madhushah999@hotmail.com)

# STAGING REGULATIONS

## PAVILION ACCESS & CONDUCT

- Registration ID badges **MUST** be worn at all times.
- Only competitors and officials will be allowed in the Pavilion during staging times.
- Mobile phones **must** be switched off during all competition staging times.
- No assistance will be given regarding preparation or construction of an exhibit (except if required to lift a heavy object, and only then at the discretion of the head steward).
- Competitors must place their waste material in bags provided by the Show Committee and remove it from the Pavilion to a designated place.
- Aerosol or spray painting is **NOT** permitted in the Pavilion or anywhere on the Showground site.
- Only battery-operated glue guns or equipment are permitted. There will be no Power Points available for use in the Pavilion.
- Competitors can bring their own refreshments into the Pavilion during competition staging times **only**. There will be light refreshments of tea/coffee and biscuits available during staging times.
- A High Visibility vest and enclosed shoes **must be worn** on site during setup and staging on Tuesday 16<sup>th</sup>, Wednesday 17<sup>th</sup> and Thursday 18<sup>th</sup> March. Competitors will be provided with a high-visibility vest on their first entry into the Showground at the Main Entry Gate.
- The venue has textured black/grey carpet - as per picture.

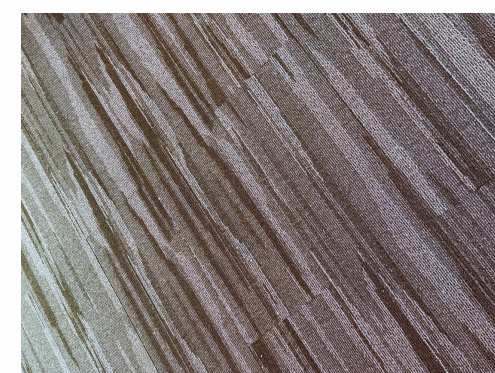

## STAGING RULES

- Competitive Class No's 1, 2, 3, 4, 6, 10, 15, 16, 17, 18, 19 & 20 must be staged in situ by the competitor, using the specified staging.
- Attachments to or moving of the staging is not permitted. However, in some classes it is permissible to move the staging within certain space specified. Please check the schedule.
- Pre-prepared components may constitute no more than 40% of the final exhibit and must not be dominant. Photos will be taken by stewards of any pre-done work for the judges.
- All exhibits must be staged within the space provided, using the specified staging, unless otherwise indicated in the schedule.
- Although every care is taken to ensure accuracy, all measurements in the staging instructions are in centimeters (cm) and are approximate.

## **STAGING TIMES**

- Staging time for competitive Class No's 1, 2, 3, 4, 6, 10, 15, 16, 17, 18, 19 & 20 will be strictly enforced from 6.00am - 12.00pm on Thursday 18th March 2027.
- Exhibits for Class No's 5, 11, & 12 may be:
  - Pre-posted for receipt by Monday 1st February 2027, or
  - Hand delivered to the venue on Wednesday 17th March 2027 between 4.00pm - 6.00pm by a registered delegate.
- Class No's 7, 8, 9, 13, & 14 will be staged on Wednesday 17th March between 4.00pm & 6.00pm.
- Imposed Class No's 21, 22, 23 & 24 will be staged as per the timetable.
- Information will be supplied when accepted into the class.

## **JUDGING & AWARDS**

- Judging will be conducted according to the International World Flower Show Rules and Regulations in this schedule.
- No persons other than Judges, Stewards and Show Officials will be permitted in the Pavilion whilst judging is in progress.
- The Judges' decision is final.

## **EXHIBIT MAINTENANCE**

- Competitors are required to maintain their exhibits in prime condition for the duration of the show.
- Maintenance of exhibits may be carried out from 7.00am - 9.00am each morning.
- The Committee reserves the right to change or remove faded plant material.

# GENERAL INFORMATION

## INSURANCE & LIABILITY

- All competitors' property is at their own risk, and they must be responsible for their own insurance.
- The Australian Floral Art Association and the World Association of Floral Artists do not accept any liability for loss or damage to competitors' property.

## DISMANTLING

- Dismantling time for all competitors is Monday 22nd March 2027 from 7.00pm - 8.00pm.
- To ensure security of competitors and their property, the Pavilion will be completely vacated from 7.00pm except for members of the WAFA Australia Show Committee.
- Competitors wearing their Registration ID badges will be admitted at 7.15pm.
- Any exhibits or parts thereof remaining unattended in the Pavilion after 8.00pm will be deemed abandoned and will be disposed of.
- Pre-done exhibits will not be returned unless you arrange for a delegate to collect on your behalf.

## PHOTOGRAPHY

The official photographer will automatically photograph:

- first, second and third places in each class
- special award winners
- honorary exhibits

Copies will be available for purchase at the Show.

You may only use hand-held cameras, without separate lighting, tripods or other supports. No photographs may be used commercially.

**TO KEEP THE EXCITEMENT ALIVE, WE ASK THAT YOU REFRAIN FROM POSTING ANY PHOTOS OF DESIGNS ON SOCIAL MEDIA UNTIL AFTER THE AWARDS CEREMONY.**

# PLANT MATERIAL INFORMATION

Australia has some of the toughest biosecurity and plant import rules in the world to protect our environment, agriculture, and economy. Very strict biosecurity laws apply.

- Please refer to the Australian Government website [www.bicon.agriculture.gov.au](http://www.bicon.agriculture.gov.au) for further information.
- Permits and certification are required. Fresh plant material - including cut flowers, foliage, seeds, bulbs, nursery stock, and fresh produce - requires an import permit and official plant health certification from the exporting country.
- Inspection on arrival. All permitted plant material is subject to inspection by Australian biosecurity officers. Items may be treated, confiscated, or destroyed if they do not meet entry conditions.
- Prohibited items: fruits, vegetables, and seeds are not allowed entry at all. Soil, potting mix, and untreated plant products are strictly prohibited.
- International mail-in restrictions. Plant material sent by post or courier must be clearly marked for quarantine inspection. Packages will be opened and checked by Australian Customs before release. Include a list of botanical materials used in your design.
- Risks of non-compliance. Attempting to bring in undeclared or prohibited plant material can result in fines, confiscation, and possible prosecution.

# **PLANT MATERIAL INFORMATION**

World Association of Floral Artists Australia and the Australian Floral Art Association take no responsibility for any action taken by Australian Customs.

**Competitors and delegates are strongly advised to avoid bringing any fresh horticultural material into Australia.**

- Competitors are responsible for providing all their own plant material (except for the Imposed Class No's 21, 22, 23 & 24)
- The Sydney Flower Market is approximately 3km from the Showground and plant material can be ordered from the traders in the market.
- The WAFA Australia Committee are unable to assist competitors/exhibitors source plant material and sundries in any way.
- Please give clear instructions to the market trader/s to ensure your order is clearly labelled with your name and WAFA World Flower Show.
- You will need to collect your flower order/s from the Flower Market.
- All payments for plant material are to be made directly to the supplier in Australian Dollars and the WAFA Australia Committee will not be involved in this in any way.

# SYDNEY FLOWER MARKET TRADERS

The Sydney Flower Market is Australia's largest flower market and is open to the public offering a wide variety of fresh-cut flowers from local growers and wholesalers. The market features a diverse range of flowers, including seasonal blooms, potted plants and florist supplies. There are approximately 45 traders operating in the market and they primarily supply florists in Sydney, regional New South Wales, and the Australian Capital Territory. All the traders must be flower growers; however some also act as wholesalers or agents for other growers throughout Australia.

A comprehensive directory of traders is available as a separate document on our website. [www.wafaaustralia.com](http://www.wafaaustralia.com)

---

## Wildflower Country

They bloom where the land turns quiet,  
small sparks against the sunburnt earth.  
Scattered by an unseen hand.

Wattle drifts its yellow light,  
soft as morning sun on skin.

Kangaroo paws lift velvet fingers  
toward whatever sunlight the day will spare.

And tiny orchids wait in the shadows  
for someone patient enough to see them.

They thrive without asking,  
teaching us how beauty endures  
in the toughest places.

And when you walk among them,  
may you carry a little of their strength with you,  
bright as a petal caught in your sleeve.

---

All information is correct at the time of publication

# PROHIBITED PLANT MATERIAL

Parramatta City Council have strict regulations regarding priority weeds within their Council area. These plant species **CANNOT** be used in any form or any part in any floral design.

Common name	Scientific name
Alligator weed	Alternanthera philoxeroides
Gamba grass	Andropogon gayanus
Pond apple	Annona glabra
Giant reed	Arundo donax
Climbing asparagus	Asparagus africanus
Bridal veil creeper	Asparagus declinatus
Sicklethorn	Asparagus falcatus
Ming fern	Asparagus macowanii var. Zuluensis
Asparagus fern	Asparagus virgatus
Chinese violet	Asystasia gangetica subspecies. Micrantha
Groundsel bush	Baccharis halimifolia
Coral creeper	Barleria repens
Kochia	Bassia scoparia (excluding subsp. trichophylla)
Cabomba	Cabomba caroliniana
Mysore thorn	Caesalpinia decapetala
Spotted knapweed	Centaurea stoebe subsp. australis
Black knapweed	Centaurea x moncktonii
Green cestrum	Cestrum parqui
Siam weed	Chromolaena odorata
Boneseed	Chrysanthemoides monilifera subspecies. monilifera
Koster's curse	Clidemia hirta
Pampas grass	Cortaderia species
Rubber vine	Cryptostegia grandiflora
Scotch/English Broom	Cytisus scoparius
Cat's claw creeper	Dolichandra unguis-cati
Kei apple	Dovyalis caffra
Anchored water hyacinth	Eichhornia azurea

Common name	Scientific name
Water hyacinth	Eichhornia crassipes
Horsetails	Equisetum spp.
Sea spurge	Euphorbia paralias
Glory lily	Gloriosa superba
Senegal tea	Gymnocoronis spilanthoides
Kidney leaf mud plantain	Heteranthera reniformis
Water star grass	Heteranthera zosterifolia
Water poppy	Hydrocleys nymphoides
Hydrocotyl/Water pennywort	Hydrocotyle ranunculoides
Hygrophila	Hygrophila costata
East Indian hygrophila	Hygrophila polysperma
Hymenachne	Hymenachne amplexicaulis
Lagarosiphon	Lagarosiphon major
Frogbit / Spongeplant	Limnobium spp. (all species)
Yellow burrhead	Limnocharis flava
Sicilian sea lavender	Limonium hyblaenum
Ludwigia	Ludwigia peruviana
Miconia	Miconia spp. (all species)
Mikania vine	Mikania micrantha
Mimosa	Mimosa pigra
Eurasian water milfoil	Myriophyllum spicatum
Mexican feather grass	Nassella tenuissima (syn. Stipa tenuissima)
Serrated tussock	Nassella trichotoma
Nodding thistle	Nodding thistle Carduus nutans
African olive	Olea europaea subsp. Cuspidata
Tiger pear	Opuntia aurantiaca

# PROHIBITED PLANT MATERIAL

Parramatta City Council have strict regulations regarding priority weeds within their Council area. These plant species CANNOT be used in any form or any part of any floral design.

Common name	Scientific name
Broomrape	Orobanche spp. (all species except the native O. cernua var. australiana and O. minor)
Skunk vine	Paederia foetida
Parkinsonia	Parkinsonia aculeata
Parthenium weed	Parthenium hysterophorus
Leaf cactus	Pereskia aculeata
Chinese knotweed	Persicaria chinensis
Hawkweed	Pilosella spp (all species)
Water lettuce	Pistia stratiotes
Kudzu	Pueraria lobata
White blackberry / Mysore raspberry	Rubus niveus
Grey willow	Salix cinerea
Black willow	Salix nigra
Salvinia	Salvinia molesta
Holly-leaved senecio	Senecio glastifolius
Giant devil's fig	Solanum chrysotrichum
Tropical soda apple	Solanum viarum
Spanish broom	Spartium junceum
Singapore daisy	Sphagneticola trilobata
Giant rats tail grass	Sporobolus pyramidalis
Water soldier	Stratiotes aloides
Witchweed	Striga spp. (except the native S. parviflora)
Water caltrop	Trapa spp. (all species)
Gorse	Ulex europaeus
Karoo acacia	Vachellia karroo (syn. Acacia karroo)
Prickly acacia	Vachellia nilotica (syn. Acacia nilotica)

*Parramatta City Council is the local ruling authority where the Sydney Showground is located. This comprehensive list of prohibited plant material is provided by the Parramatta City Council and there are severe fines should any of these plants be used in any designs.*



# VENUE



The Sydney Showground precinct, located in the heart of Sydney Olympic Park, is an expansive state of the art facility with ample space and modern amenities. It is the perfect setting for our grand event, easily accessible by public transport and surrounded by beautiful parks. A dynamic environment for all delegates.

Use the red lines on the map to find your way between key WFA World Flower Show Program Locations:

- ★ **Workshop Venue** - follow the red line from Olympic Park Train Station to the Workshop Venue in the Woolworths Fresh Food Dome. There will be signs to the Sommerville & Pearson Rooms on Level 1.
- ★ **Competition & Display Venue** - continue along the red line to the Flower & Garden Pavilion. Entry to the Southee Pavilion is Hall 5 through the curved front doors.
- ★ **Gala Dinner Venue** - follow the red line to the Vincent Fairfax Stand within the Main Arena, near the giant Ferris Wheel.
- ★ **Seminar Reunion Venue** - follow the red line to the foyer under the Arena View Bar, then upstairs to the See Rooms.



# SYDNEY FLOWER MARKET

The Sydney Flower Market is approximately 3km from the Showground. The flower market is located in Shed F within the Sydney Market Precinct and is open to the public from 6am - 10am Monday, Wednesday & Friday - arrive early. If catching a taxi/bus, we suggest have them drop you outside the main gate and you walk into the markets. For your safety, please be alert and aware of the many vehicles and forklifts within the market area. When crossing any road look left and right.

The flower market in Shed F is easily accessed via Austin Avenue, off Marlborough Road or Centenary Drive.

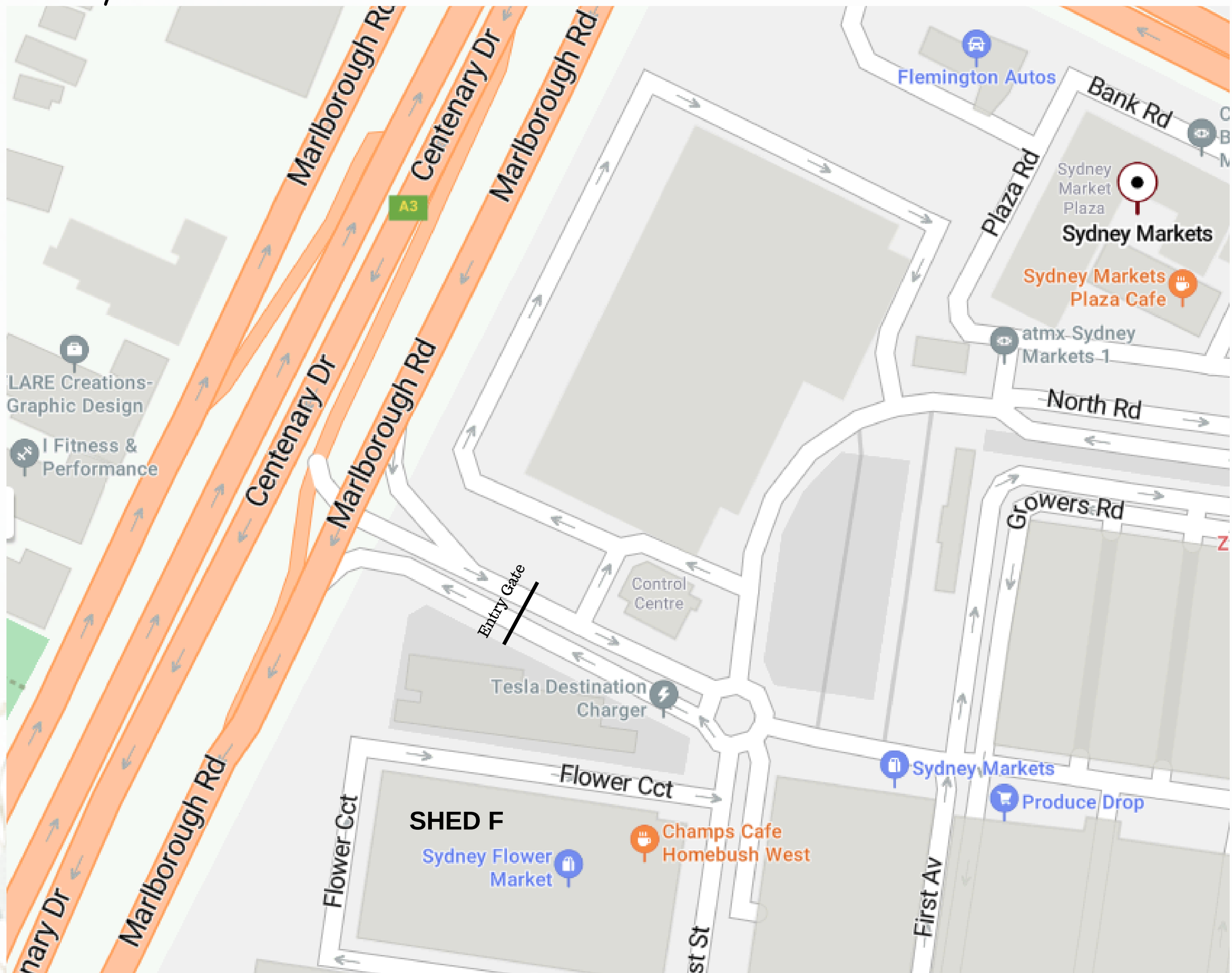

Competitors are responsible for providing all their own plant material (except for the Imposed Class No's 21, 22, 23 & 24).

The WAFA Australia Management Committee are unable to assist in obtaining plant material or sundries in any way.

**WEARING A HIGH-VISIBILITY VEST IS SUGGESTED** for safety reasons when you are in the flower market. Enclosed shoes are recommended.

Competitors will be provided with a high-visibility vest on their first entry into the Showground at the Main Entry Gate.

**TAKE CASH** Like all markets, cash is king. Not all vendors have a card machine, and although there are ATMs on-site, it is advisable to take cash with you.

**Australian Dollars** are the only accepted currency.

# CLASS DISTRIBUTION

## SOUTHEE PAVILION, HALL 5 - FLOWER & GARDEN PAVILION

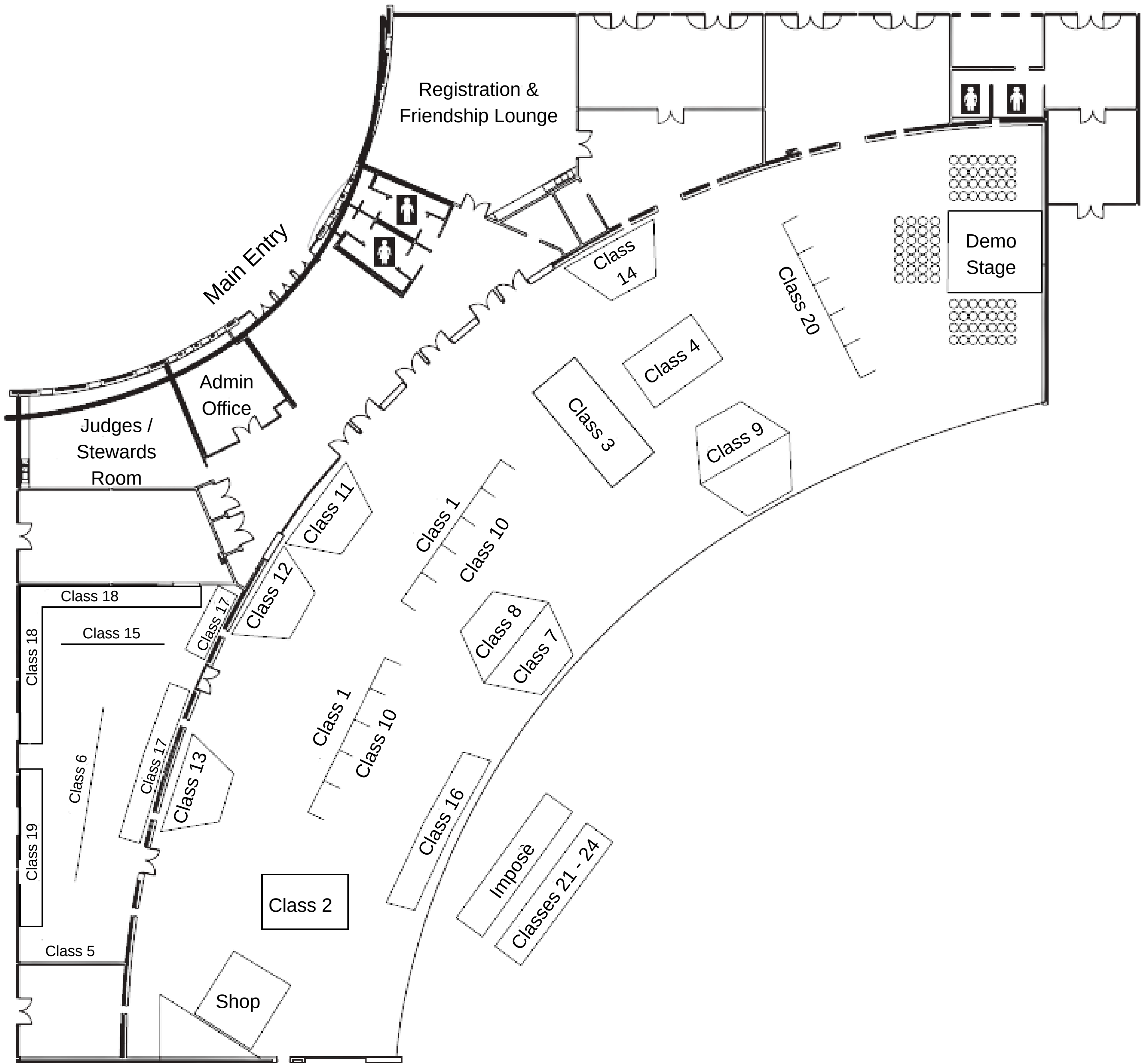

# LAND OF CONTRASTS

## CLASS 1

### A LAND OF CONTRASTS

Sponsored by:  
The Canberra Flower Club,  
Australian Capital Territory

- Exhibit staged on a supplied grey semi-circle 215cm wide, depth in the centre is 107 cm which is placed on the floor
- May be staged by 2 people
- Height is optional
- Backing colour black
- Floor carpet is black and grey
- To be viewed and judged from both front and sides

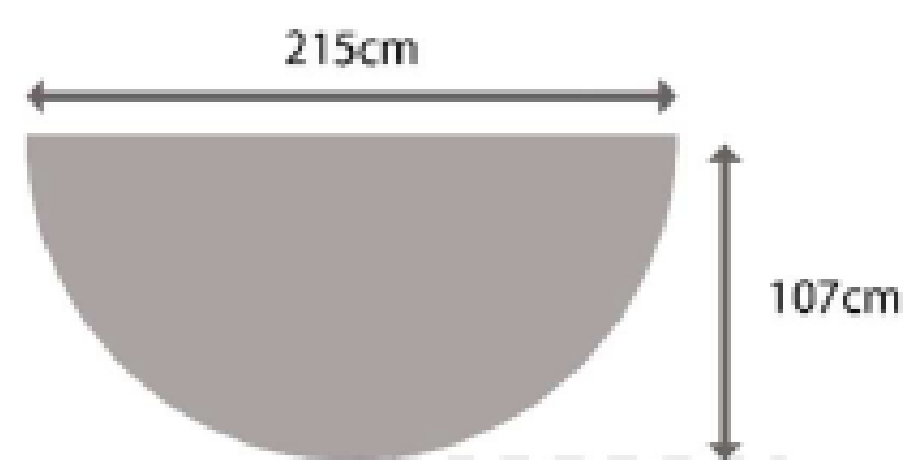

## CLASS 2

### A SOUTHERLY BUSTER

A colloquial name given to an abrupt wind which arrives suddenly and with force, cooling the temperature down after a hot summer's day in Sydney.

Sponsored by:  
The Gloucester Floral Art Club,  
New South Wales

- **A Suspended design**
- The exhibit is to be suspended from the ring attached to the top of the black metal circular frame that is 90cm in diameter.
- The circular frame is positioned on a supplied metal rod, fixed on a black 46cm square base
- Height of the metal rod is 95cm
- Space allowed – width and depth of the design **must** be within the 90cm circle
- Floor carpet is black and grey
- The weight of the design should not exceed 4kg
- To be viewed and judged from all around

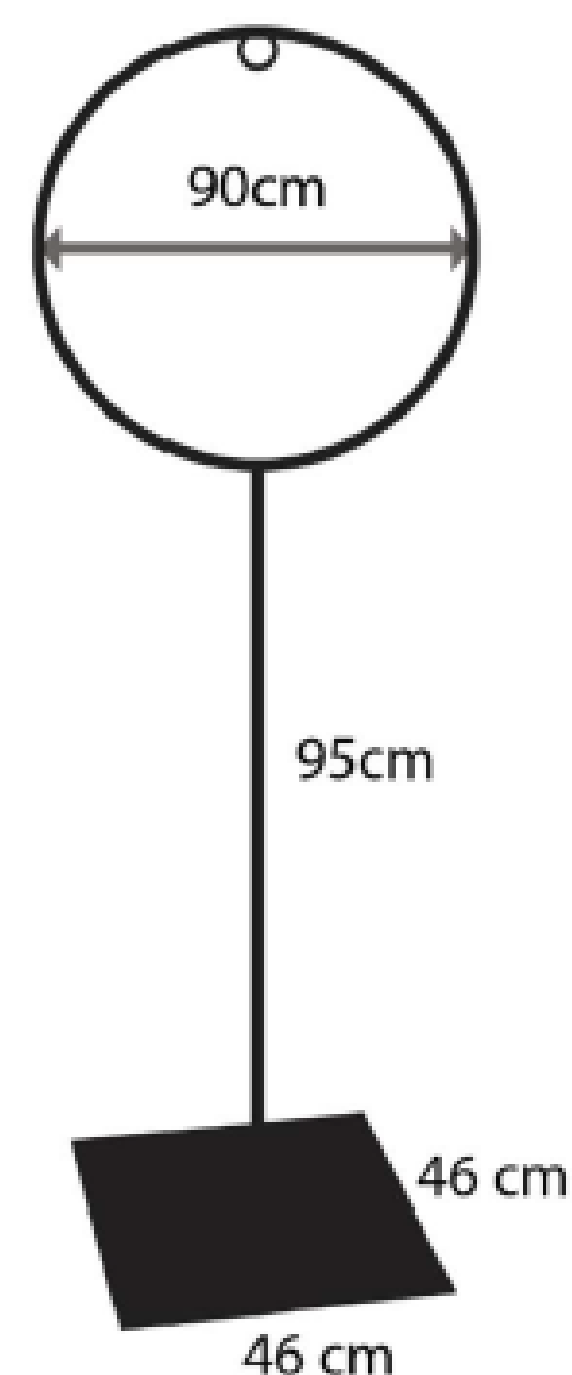

# LAND OF CONTRASTS

## CLASS 3

### THE GREAT BARRIER REEF

Sponsored by:  
New South Wales Floral Art Association

- Exhibit staged on a supplied black metal mesh panel 100 cm wide x 200cm high, with a 30cm metal base support on each side
- A base is optional but not provided
- May be staged by 2 people
- Overall space allowed: 120cm x 120cm x height unlimited
- Floor carpet is black and grey
- Black mesh panel can be placed at competitor's discretion within the allocated space
- To be viewed and judged from all around

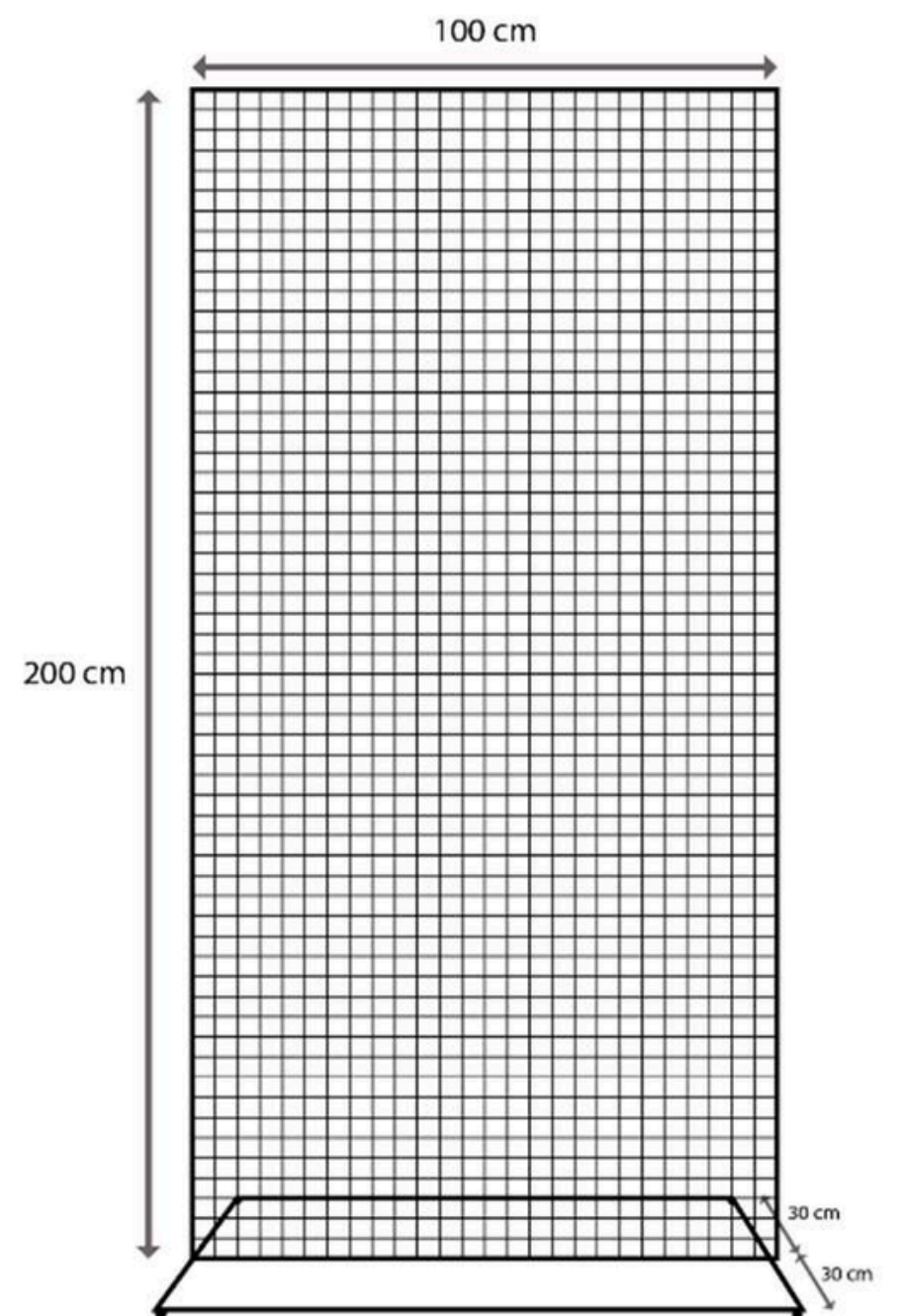

## CLASS 4

### OPAL FIRE

Opal Fire is a term given to Australian Opals, which describes the brilliant play of colour within the stone, especially when the stone is moved around. While some opal fire can be red or orange, it can also include greens, blues and yellows and more.

Sponsored by:  
Mandurah Floral Art Group,  
Western Australia

- Exhibit staged on a supplied grey cube 60 cm x 60 cm x 60cm
- Space allowed: 100cm x 100cm x 30cm high from the top of the cube
- Floor carpet is black and grey
- No materials should touch the floor
- Viewed and judged from above and all around

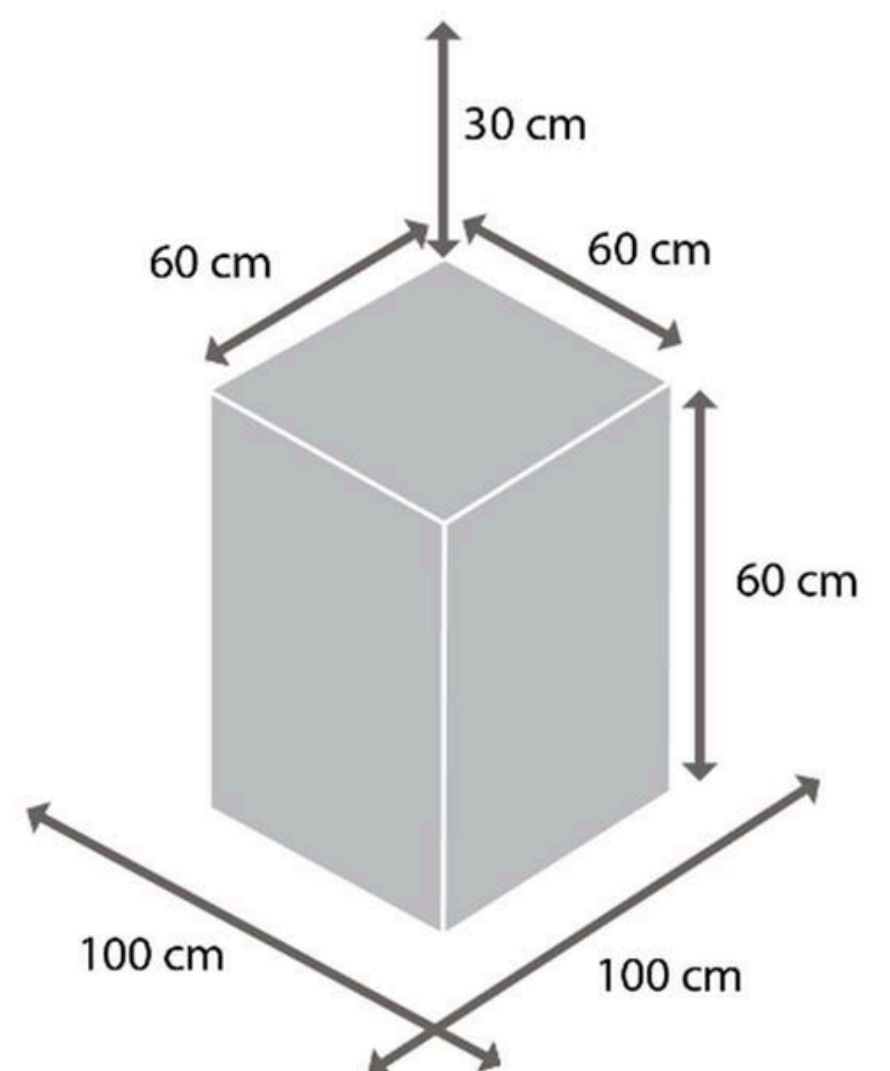

# LAND OF CONTRASTS

## CLASS 5

### DESIGNED BY NATURE

This class must be pre-done. It can be sent by mail or brought in by a person who is registered and attending the show to be staged by a steward.

Sponsored by:  
Flower Designers Club of Bunbury,  
Western Australia

- A Collage
- Space allowed: 40cm wide x 60cm x high x 20cm deep
- Staged on a black panel
- To be hung from a supplied hook
- To be viewed and judged from the front
- Maximum weight 6kg

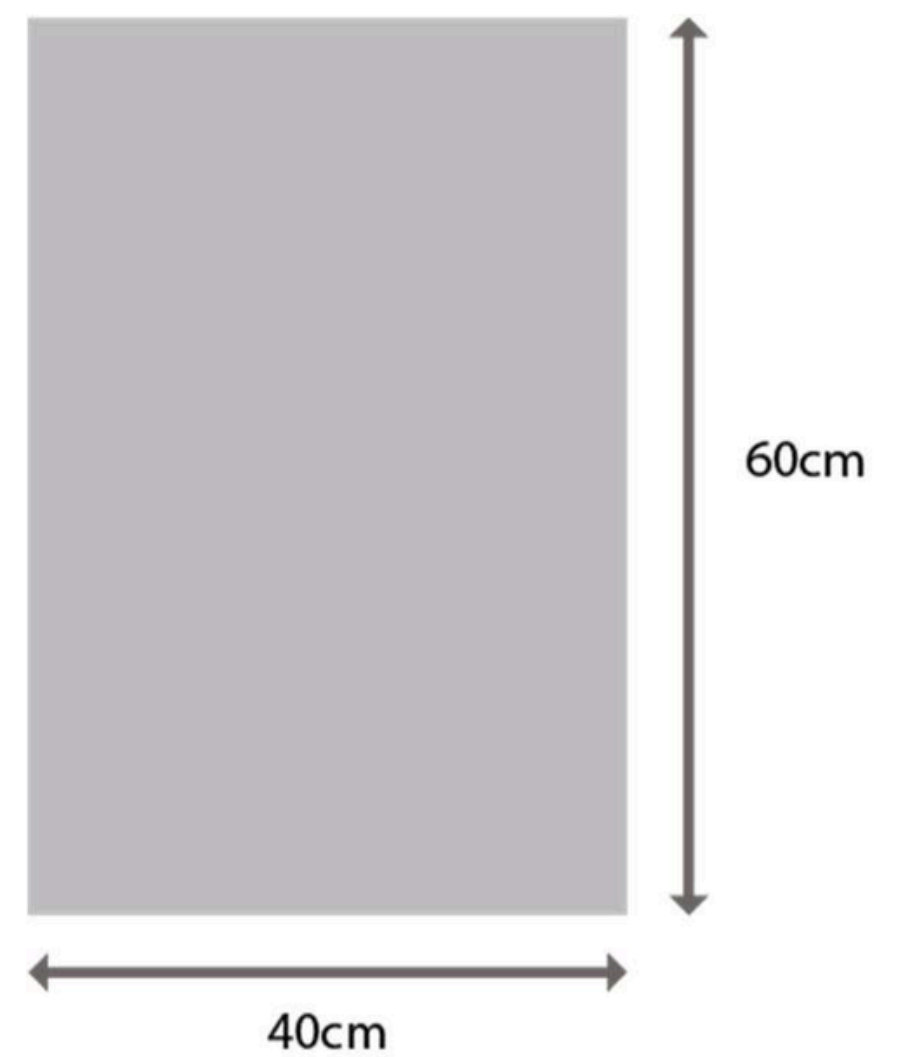

## CLASS 6

### DREAMTIME STORIES

Dreamtime stories are passed down through the generations in Australian Aboriginal culture and can be told through Art, Music and Ceremony, influencing their daily lives and interactions with the land and each other.

Sponsored by:  
Nambour Floral Art Society,  
Queensland

- Exhibit staged on a supplied grey plinth 40 cm x 40 cm x 100 cm high
- Space allowed: 100cm wide x 100cm deep x height is optional
- Plinth can be placed in any manner within the given space
- No floor placements permitted.
- Floor carpet is black and grey
- To be viewed and judged from all around

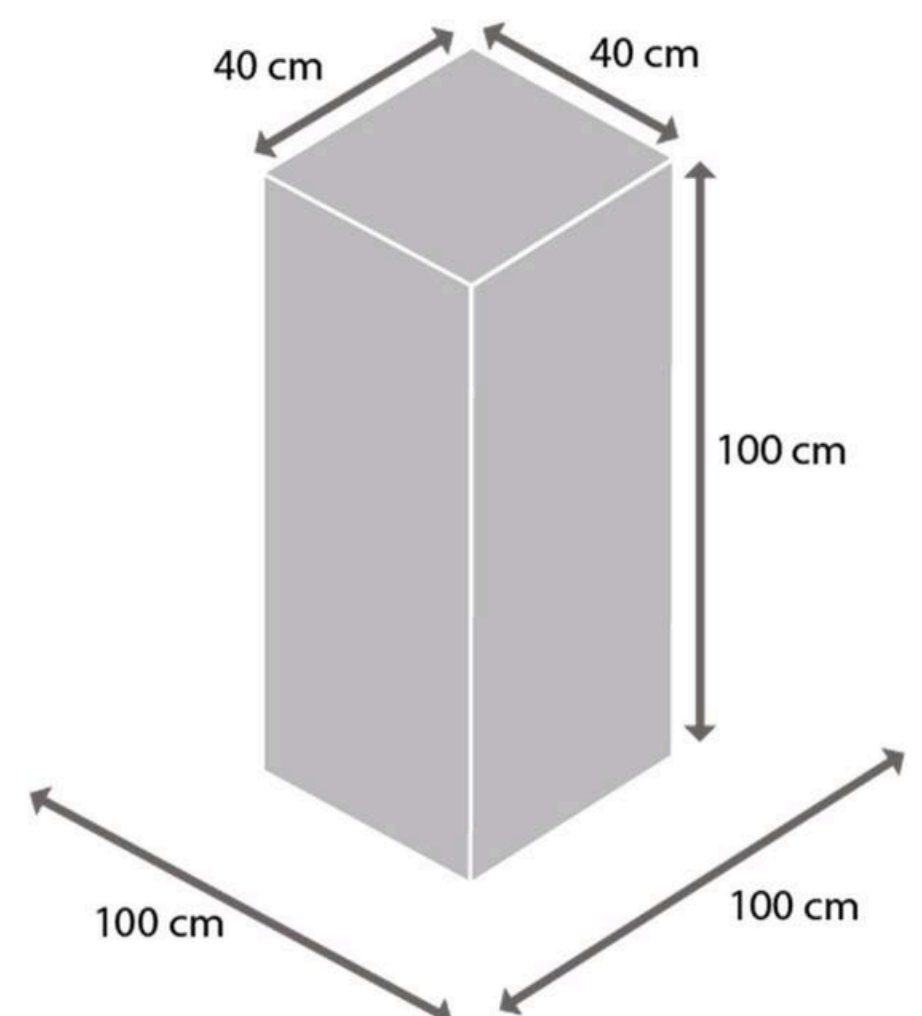

# LAND OF CONTRASTS

## CLASS 7

### ALONG THE SHORELINE

Montage is a shallow three dimensional design in which plant material and other components are used to create distinctive but visually linked layers of different elevation.

This class must be pre-done however it is to be staged by the exhibitor, final tidy-up is allowed.

**Sponsored by:  
Western Australia Floral  
Art Society**

- **A small horizontal montage exhibit**

- Exhibit staged on a supplied wooden easel 24cm high and 18 cm wide. Space between the back leg of the easel and front two legs is 15cm
- Space allowed: 43 cm wide x 20 cm high x 15cm deep
- Exhibit will be displayed on a grey tiered bench
- Has to be a lightweight exhibit. The weight of the design should not exceed 2kg
- To be viewed and judged from the front

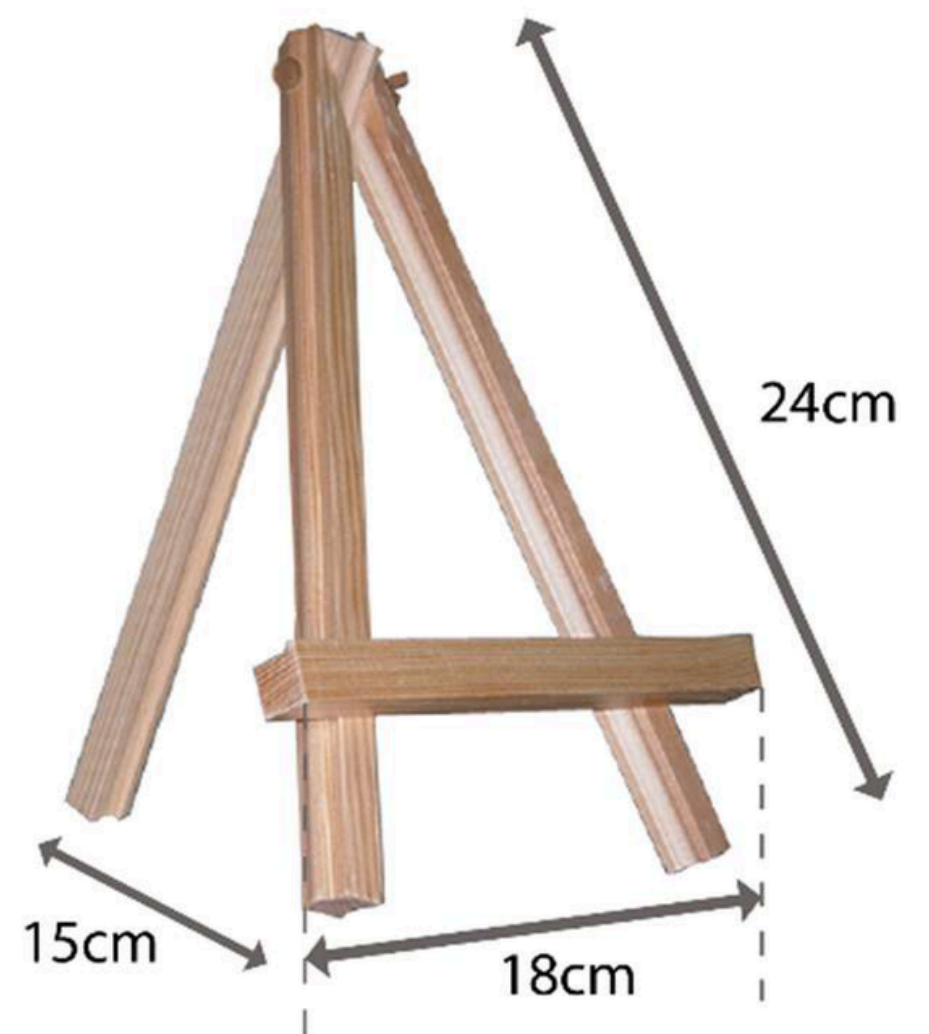

## CLASS 8

### IT'S A SCORCHER

An Australian colloquial expression to describe an exceptionally hot day, where people will say 'it's a scorcher, today'.

This class must be pre-done however it is to be staged by the exhibitor, final tidy-up is allowed.

**Sponsored by:  
Royal Horticultural Society  
of New South Wales**

- **A Petite Design**

- Exhibit staged on a supplied grey base with backing
- Space allowed: 37cm high x 25cm wide x 25cm deep
- Exhibit will be displayed on a grey tiered bench
- Viewed and judged from both front and sides

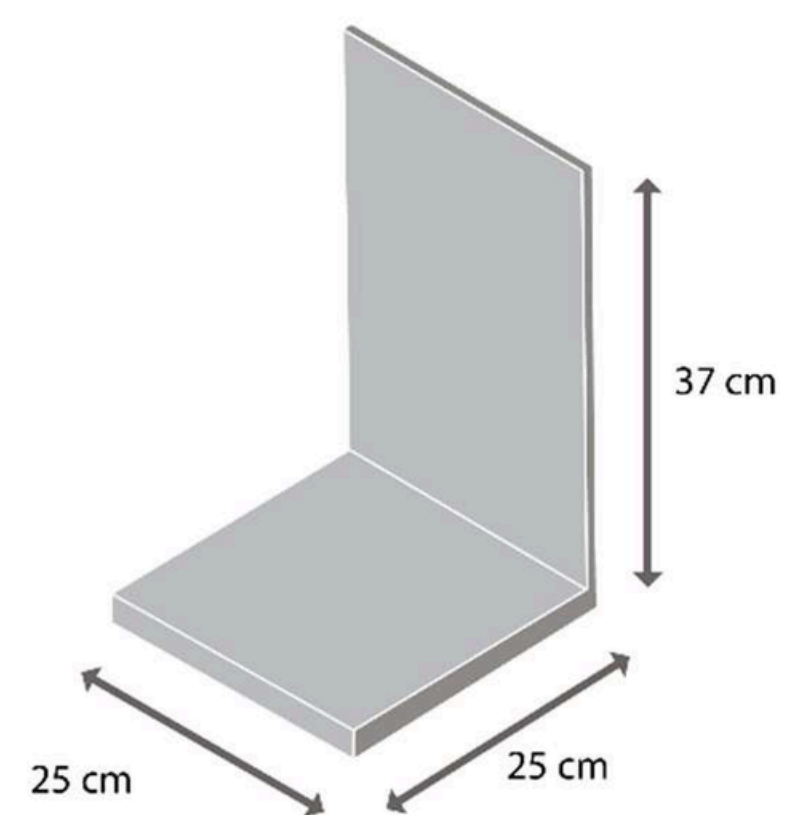

# LAND OF CONTRASTS

## CLASS 9

### PEARLIZED TO PERFECTION

This class must be pre-done however it is to be staged by the exhibitor, final tidy-up is allowed.

**Sponsored by:**  
The Contemporary Floral Design Group Mid North Coast, New South Wales

- **A Petite Design**
- Exhibit staged on a supplied grey base with backing
- Space allowed: 25cm high x 25 cm wide x 25cm deep
- Exhibit will be displayed on a grey tiered bench
- Viewed and judged from both front and sides

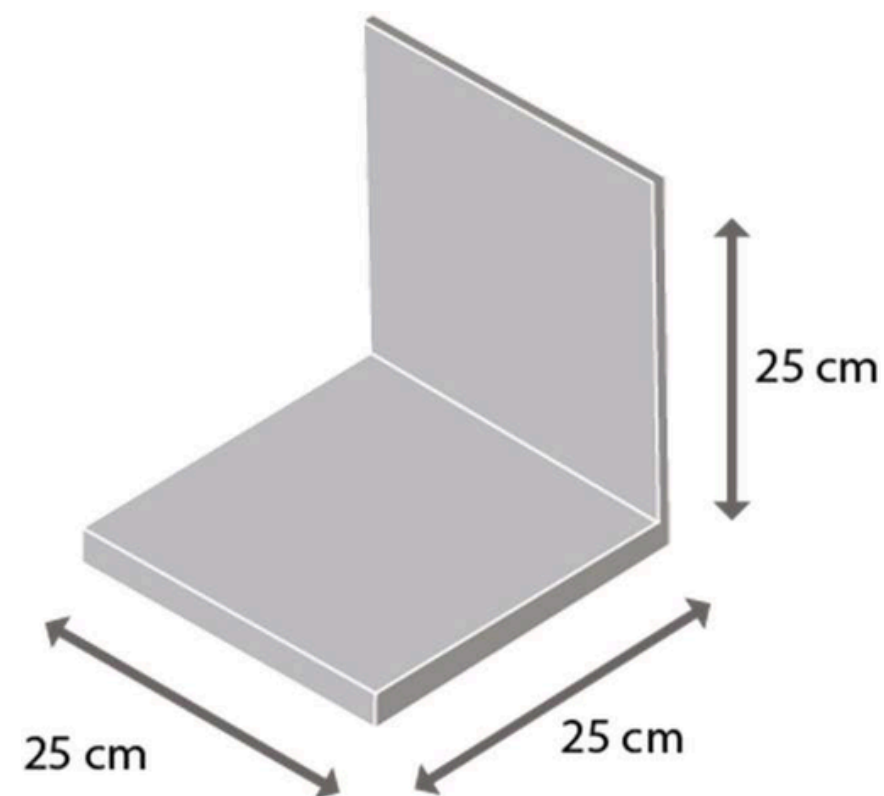

## CLASS 10

### BE ARTLANDISH

A play on the word 'Outlandish' which means to depart from what is ordinary or usual. To be unexpected.

**Sponsored by:**  
Royal Horticultural Society of New South Wales Inc

- Exhibit staged on a supplied floor metal easel. Both the easel and the backing behind the easel is painted black
- Exhibit to be staged on a 90cm circular backing board provided by the exhibitor.
- Space allowed: 100cm x 100cm x 40cm deep
- Floor carpet is black and grey
- No floor placements permitted
- To be viewed and judged from the front

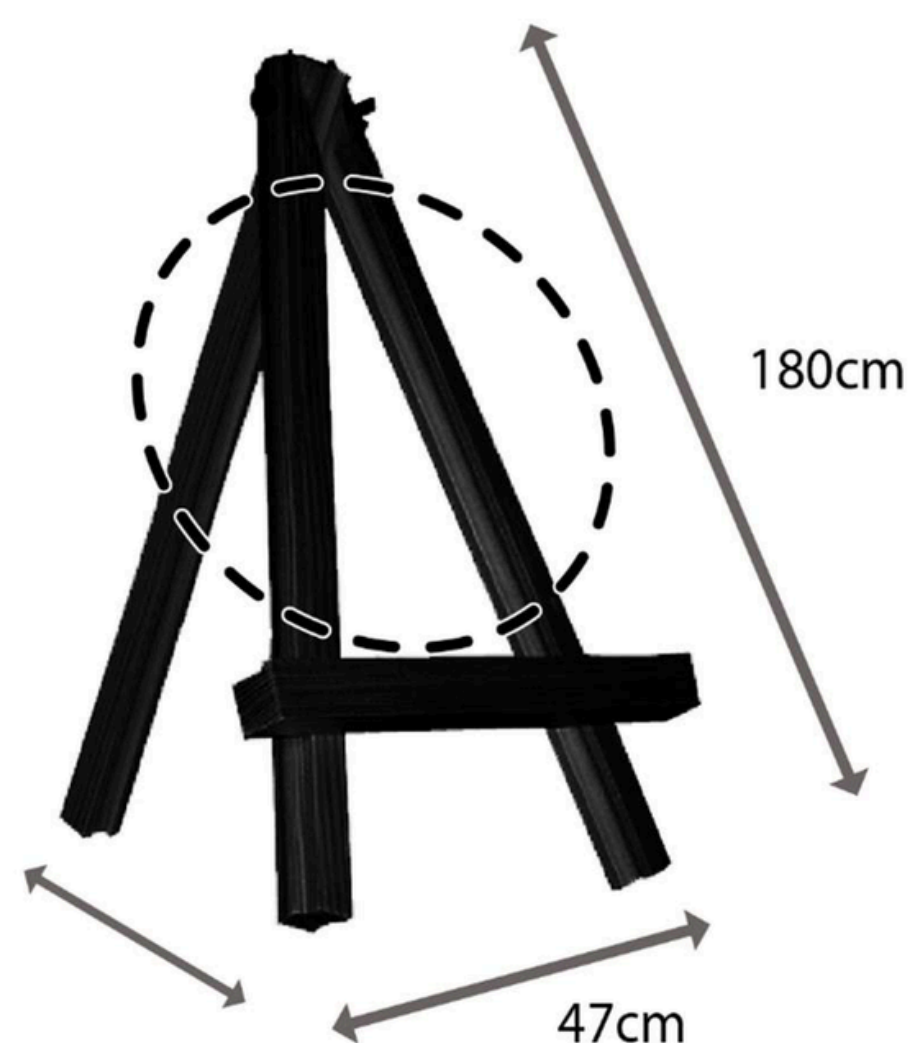

# LAND OF CONTRASTS

## CLASS 11

### PAPER PLAY

- Childrens class from 7 years – 11 years

This class must be pre-done. It can be sent by mail or brought in by a person who is registered and attending the show to be staged by a steward.

**Sponsored by:**  
**David and Sharryn Place,**  
**New South Wales**

- **A necklace**
- Staged on a supplied black necklace holder
- Space allowed: 20.5cm high, widest part of the shoulder is 13.5cm
- Exhibit will be displayed on a grey tiered bench
- Viewed and judged from the front



## CLASS 12

### RECYCLED

- Childrens class from 12 years – 16 years

This class must be pre-done. It can be sent by mail or brought in by a person who is registered and attending the show to be staged by a steward.

**Sponsored by:**  
**Flower Designers' Club of**  
**Bunbury, Western Australia**

- Space allowed: 20cm high x 30cm wide x 20 cm deep
- Exhibit will be displayed on a grey tiered bench
- Viewed and judged from the front and sides

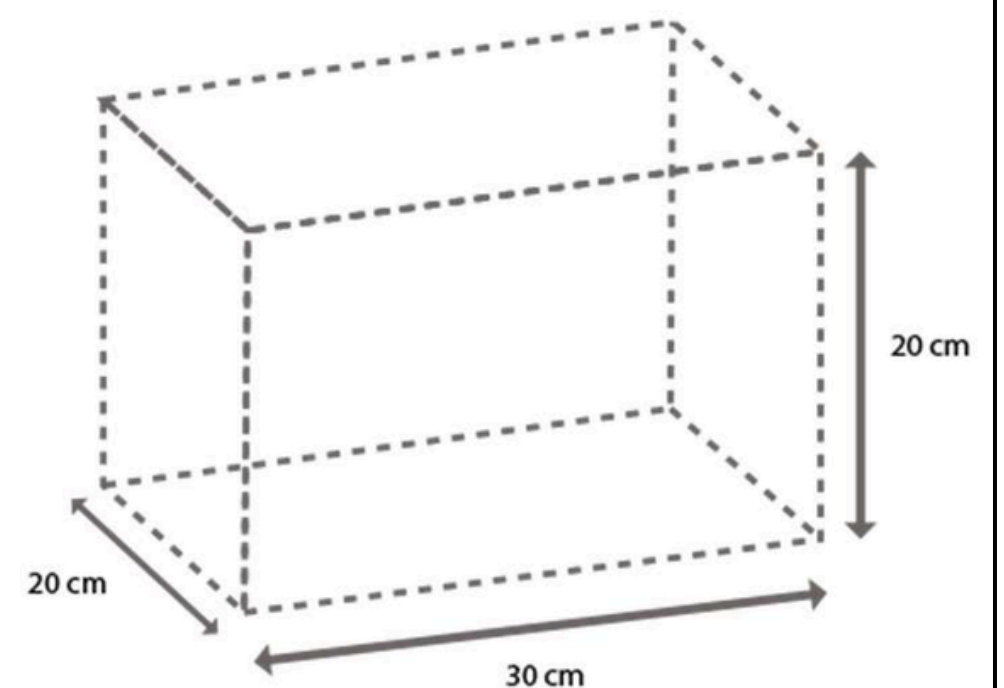

# LAND OF CONTRASTS

## CLASS 13

### DERBY DAY

The Victorian Derby Day is a well known horse racing event where everyone wears Black and White only.

This class must be pre-done however it is to be staged by the exhibitor, final tidy-up is allowed.

**Sponsored by:  
Victorian Floral Art Association**

- **A Black and white head piece**
- To be staged on a supplied model head piece painted black. The height 40cm, base width 22cm, top width 16.24cm, head circumference 51cm
- Space allowed: 60cm wide x 49cm deep x 65cm high. The exhibit may extend no more than 25cm above the top of the head piece
- Exhibit will be displayed on a grey tiered bench
- To be viewed and judged from front and sides

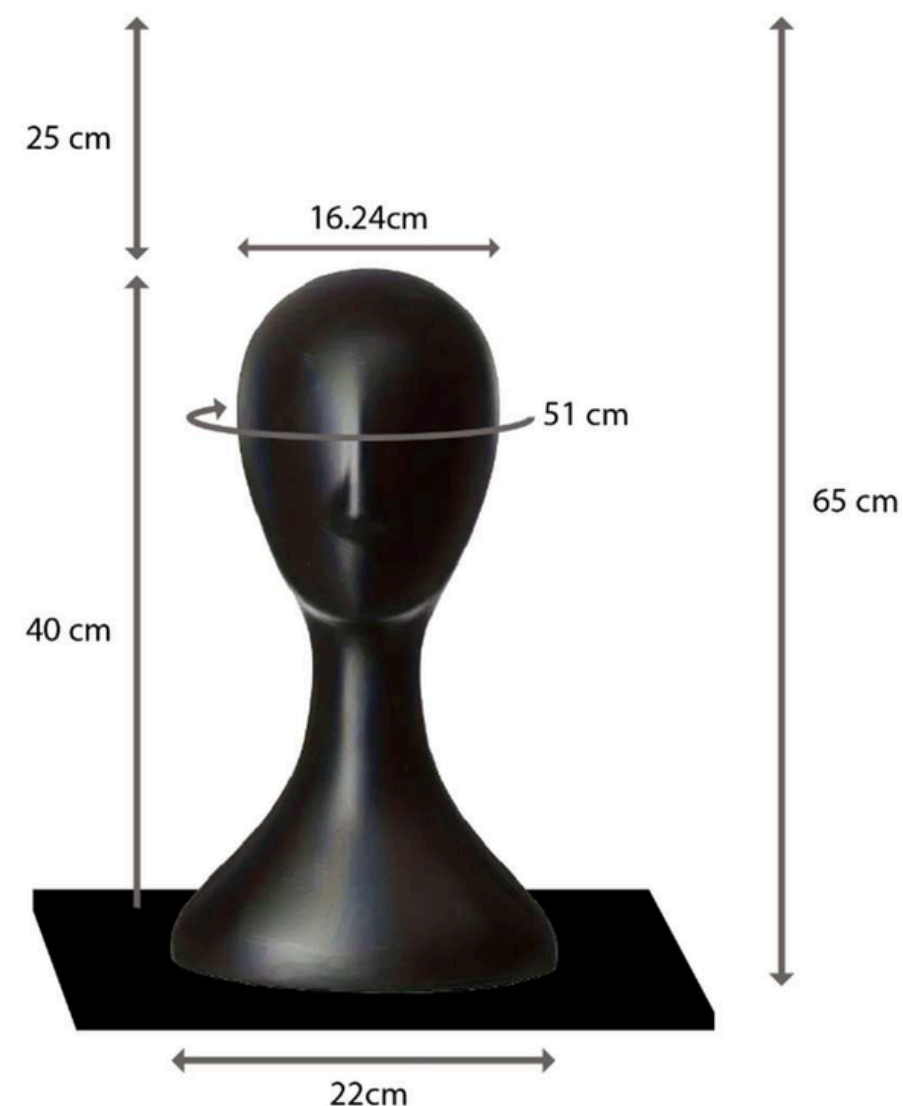

## CLASS 14

### A NIGHT AT THE OPERA

This class must be pre-done however it is to be staged by the exhibitor, final tidy-up is allowed.

**Sponsored by:  
Victorian Floral Art Association**

- **A Hand-Crafted Evening Bag**
- Space allowed: 35cm high x 30 cm wide x 40 cm deep
- Exhibit will be displayed on a grey tiered bench
- Staging to display the bag is to be supplied by the exhibitor
- To be viewed and judged from the front

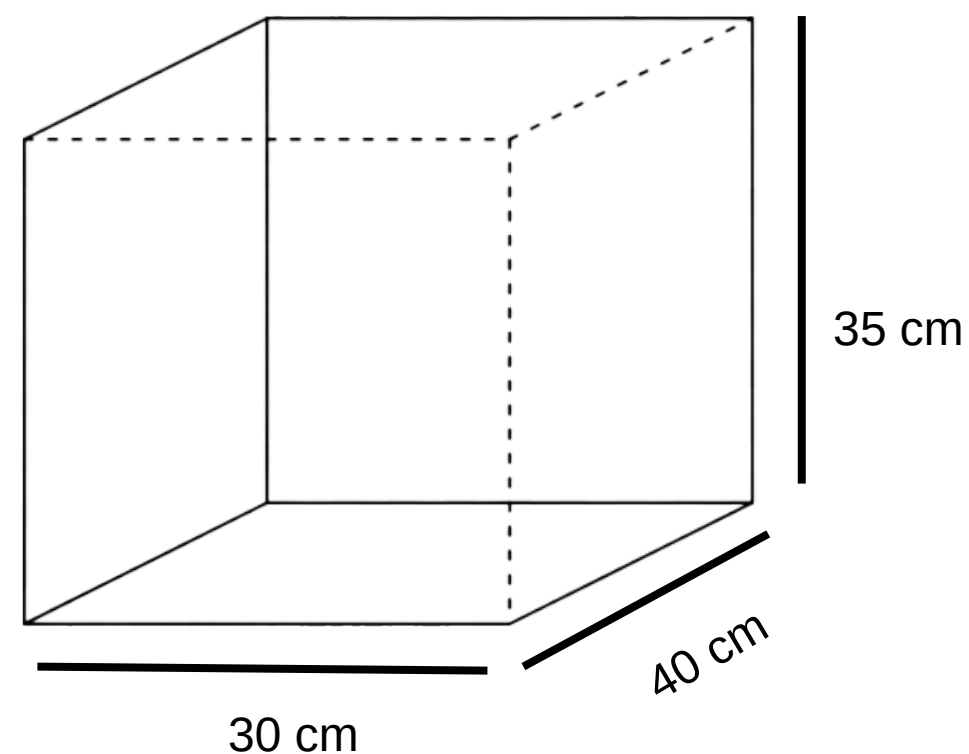

# LAND OF CONTRASTS

## CLASS 15

### A BOTANICAL LAMPSHADE

Sponsored by:  
Millicent & Districts Floral Art Club,  
South Australia

- To be staged on a supplied grey painted cube 60cm x 60cm x 60 cm
- Space allowed: 100cm x 100cm. Height optional
- No floor placements are permitted
- Floor carpet is black and grey
- To be viewed and judged from all around

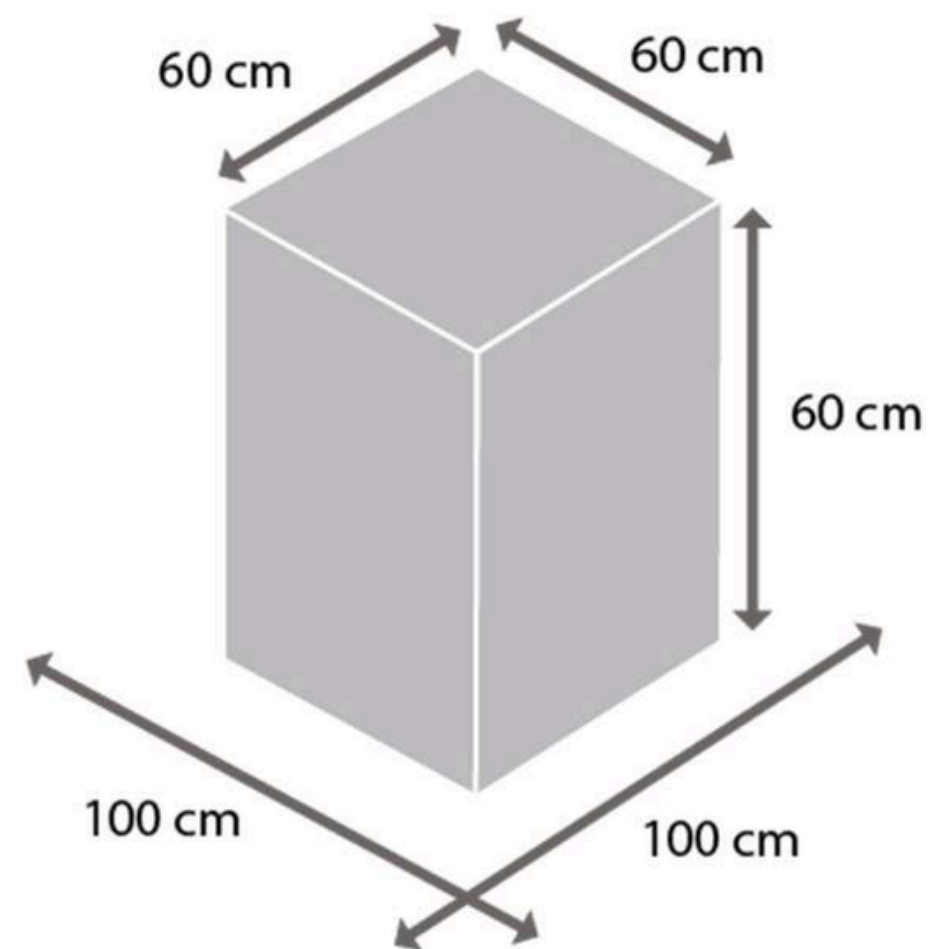

## CLASS 16

### EXPLORING THE ALTERNATIVES

Sponsored by:  
Floral Art Society of Queensland

- To be staged on a supplied grey plinth 40 cm x 40 cm x 100 cm
- Space allowed: 100cm wide x 100cm deep
- Height is optional
- Plinth can be used in any manner within the space
- No floor placements permitted.
- Floor carpet is black and grey
- Viewed and judged all around

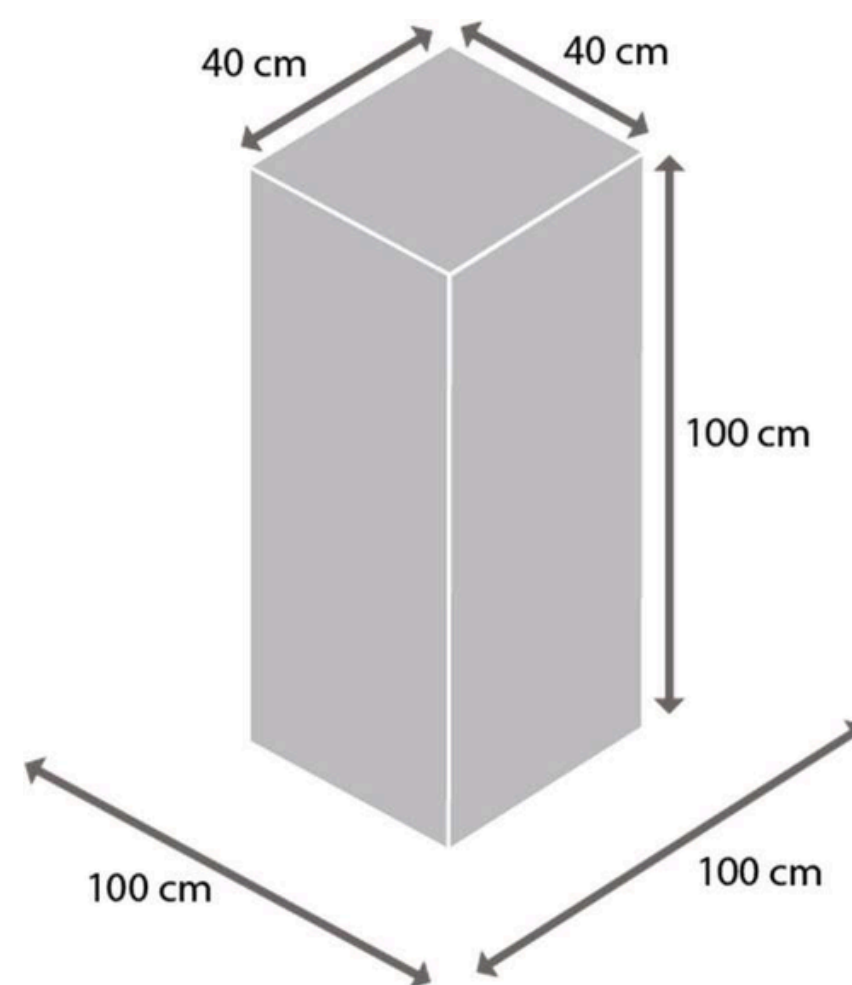

# LAND OF CONTRASTS

## CLASS 17

### FUNDAMENTAL DIFFERENCE/S

Displacement: moving the focal area or main area/s of interest away from the container or the original point or base of the design.

Sponsored by:  
The Contemporary Floral Design Group Sydney,  
New South Wales

- Displacement design
- Staged on a continuous bench 96cm from the floor
- Bench covered with black fabric and black backing
- Space allowed: 90cm wide x 90 cm deep x 144cm high
- Viewed and judged from both front and sides

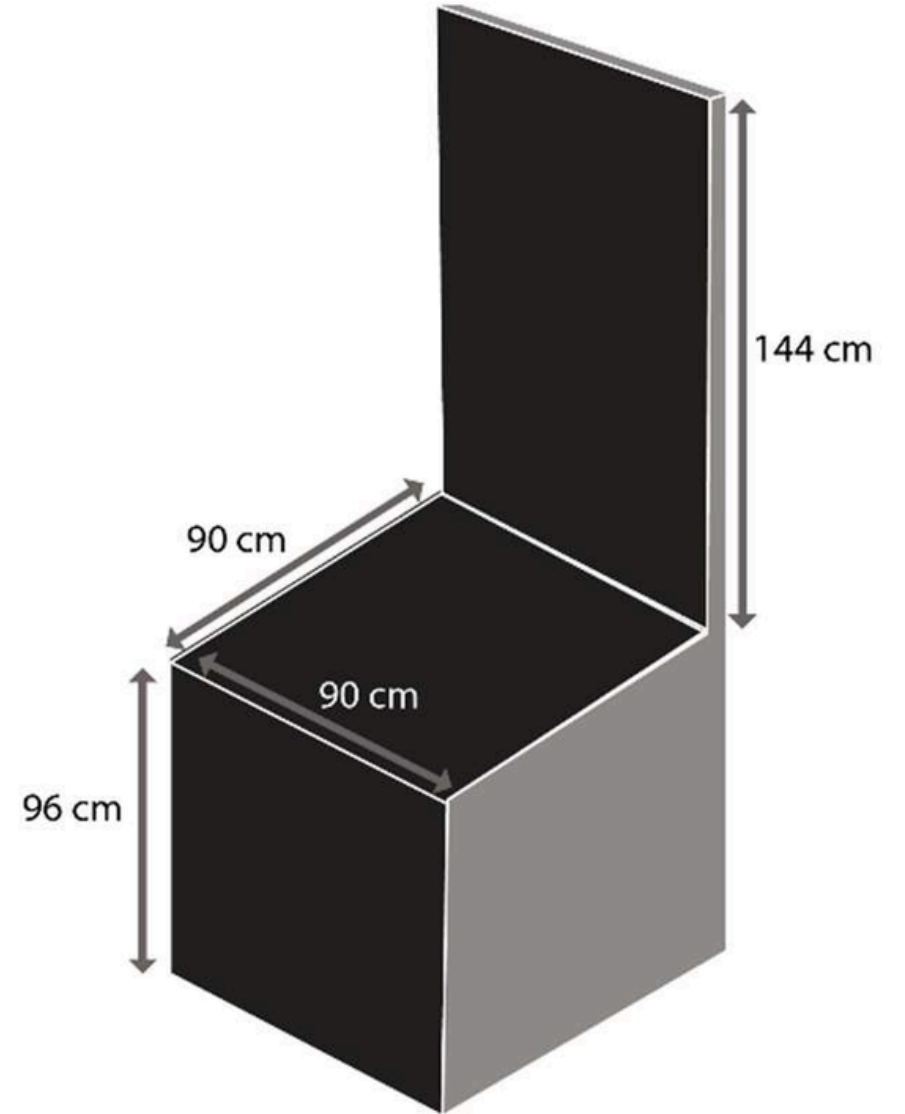

## CLASS 18

### THE RED CENTRE

A colloquial term describing the centre of Australia around Alice Springs and Uluru. It describes the terracotta-coloured earth which is rich in Iron. Uluru is the aboriginal name given to Ayers Rock. Images of the 'red centre' can be googled

Sponsored by:  
Jean Shine - Campbell Cottage,  
Western Australia

- Staged on a continuous bench 96cm from the floor
- Bench covered with black fabric and black backing
- Space allowed: 90cm wide x 90 cm deep x 144cm high
- Viewed and judged from both front and sides

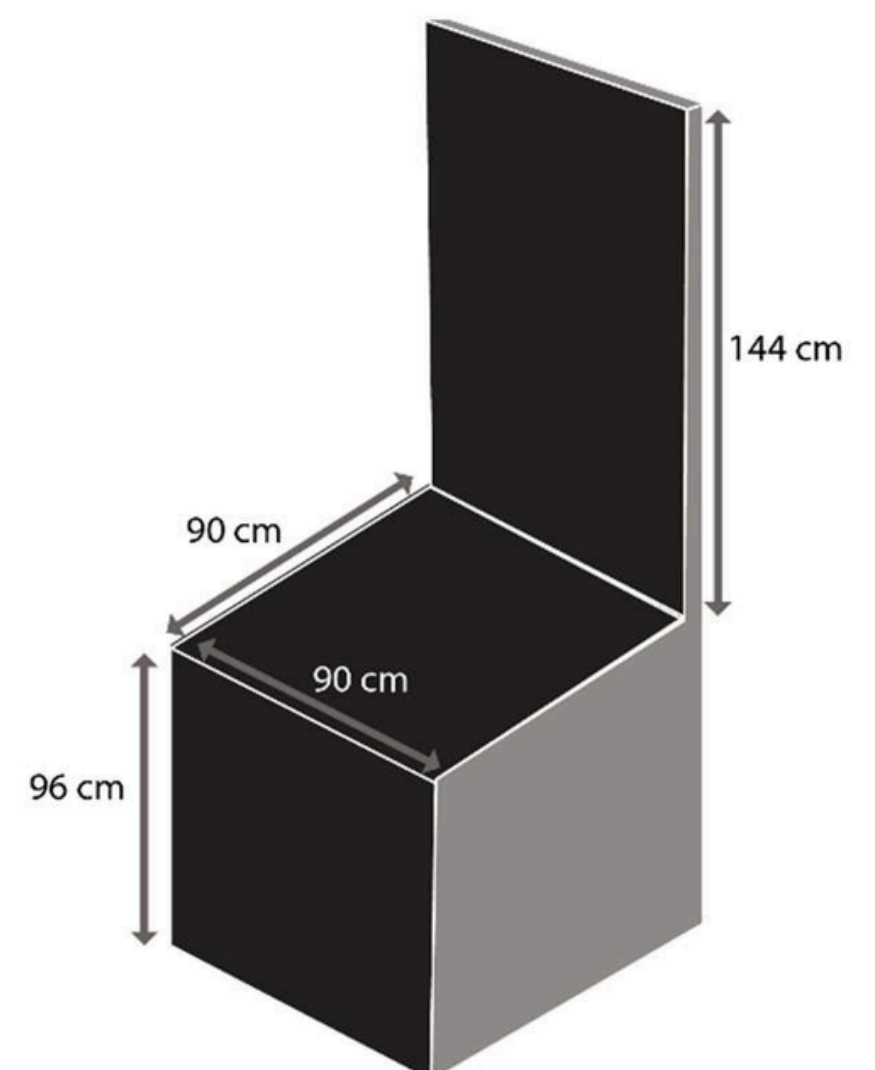

# LAND OF CONTRASTS

## CLASS 19

### A LAND DOWN UNDER

A land down under is a colloquial term given to describe Australia

Sponsored by:  
Royal Horticultural Society of  
New South Wales Inc.  
Celebrating the life of  
Margaret Brice (dec) & her  
contributions to Floral Art.

- A Traditional pedestal exhibit
- Staged on a supplied grey pedestal and grey urn
- Size of the urn is 30cm wide x 34 cm high
- Size of the pedestal is 60cm high x 30 cm wide x 30cm deep
- Space allowed: 120cm wide x 120 cm deep. Height unlimited
- Floor carpet is black and grey
- To be viewed and judged from both front and sides



## CLASS 20

### FOLDS OF NATURE

Sponsored by:  
Pilatti Bros Transport,  
Western Australia

- Foliage exhibit
- Staged on continuous bench 75 cm from the floor
- Bench covered black fabric with a black backing
- Space allowed: 60cm wide x 75 cm deep x 105cm high
- Viewed and judged from both front and sides

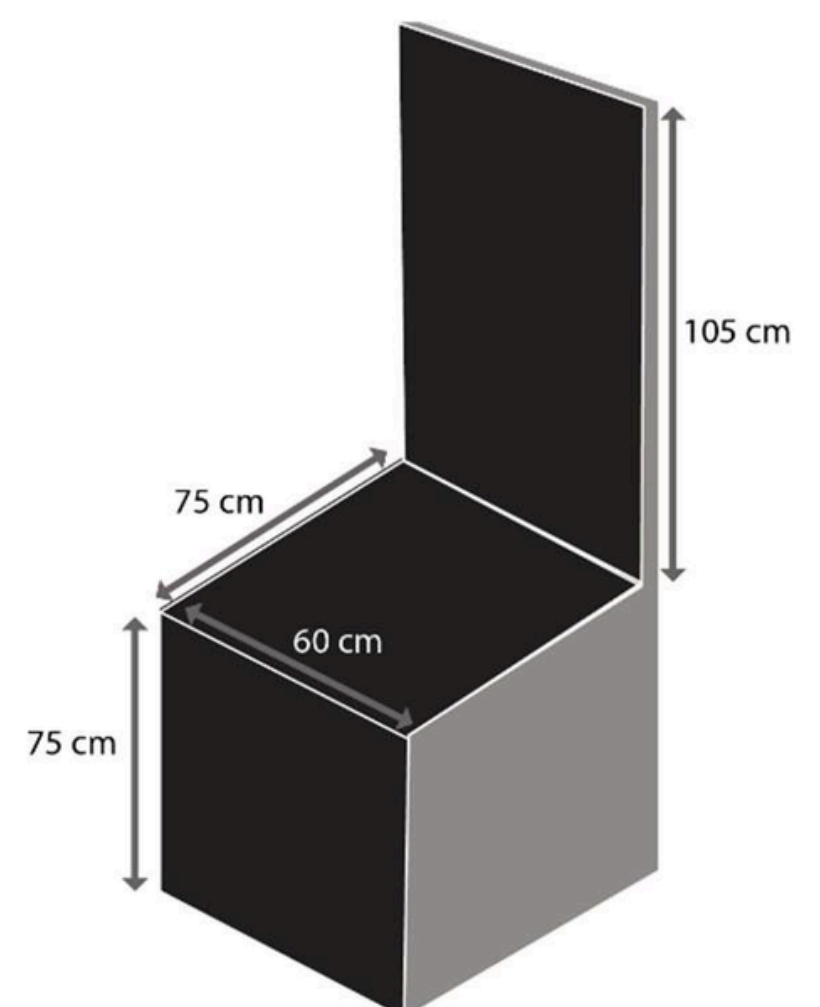

# LAND OF CONTRASTS

## CLASS 21

### BUSHFIRE MOON

The description of the moon during severe bushfires. Smoke and ash in the atmosphere make the moon appear red/orange.

Sponsored by:  
Floral Design Council of  
South Australia

- Staged on continuous bench 75 cm from the floor
- Bench covered with black fabric
- Space allowed: 90cm wide x 75 cm deep x height optional
- Viewed and judged from both front and sides

**This IMPOSÉ class will be staged on 19 March 2027**

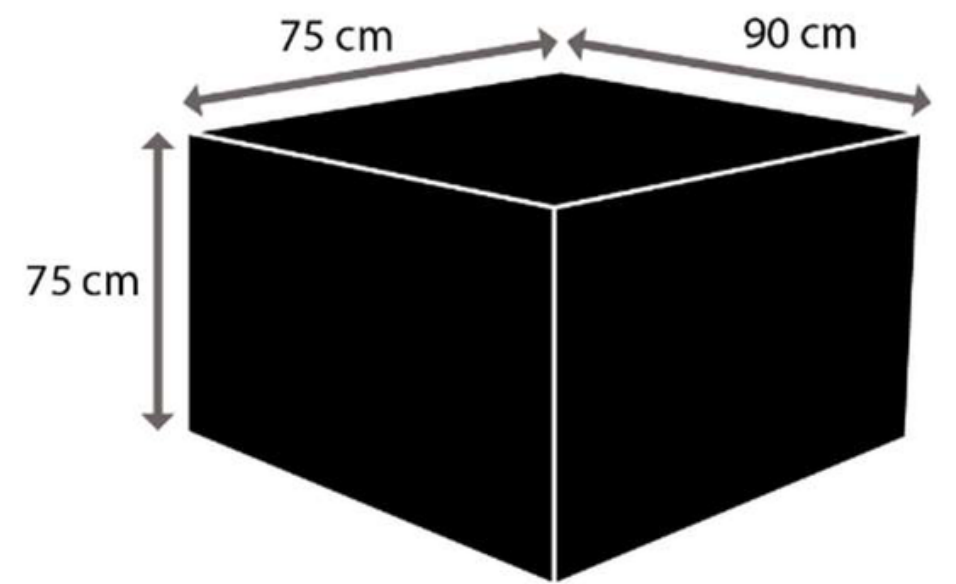

## CLASS 22

### THE DAINTREE

A World Heritage area of tropical rainforests in Far North Queensland. It is the oldest continually growing rainforest surviving on Earth.

Sponsored by:  
Woodville Academy of Floral  
Design, Unley Floral Design  
Club & Blackwood Floral Art  
Group, South Australia

- Staged on continuous bench 75 cm from the floor
- Bench covered with black fabric
- Space allowed: 90cm wide x 75 cm deep x height optional
- Viewed and judged from both front and sides

**This IMPOSÉ class will be staged on 20 March 2027**

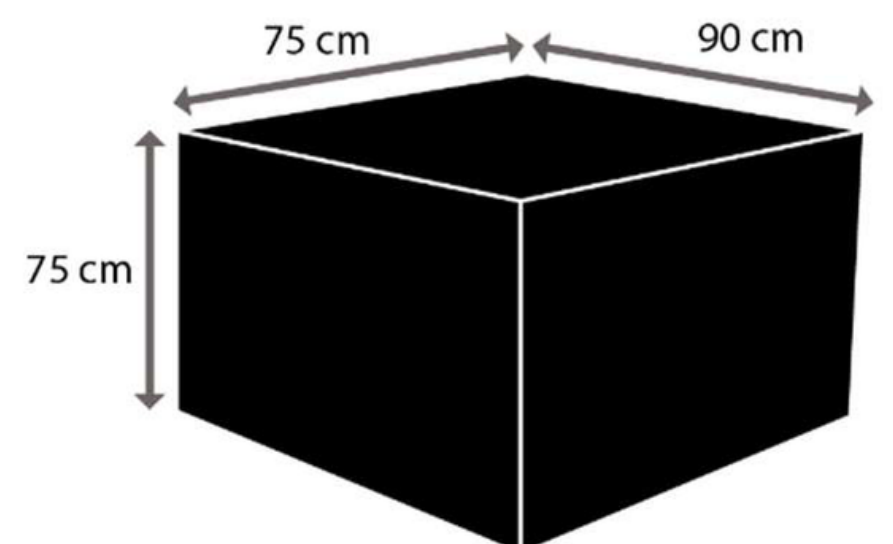

# LAND OF CONTRASTS

## CLASS 23

### AN ARID LANDSCAPE

Sponsored by:  
Victorian Floral Art  
Association

- Staged on continuous bench  
75 cm from the floor
- Bench covered with black fabric
- Space allowed: 90cm wide x  
75 cm deep x height optional
- Viewed and judged from  
both front and sides

**This IMPOSÉ class will be  
staged on 21 March 2027**

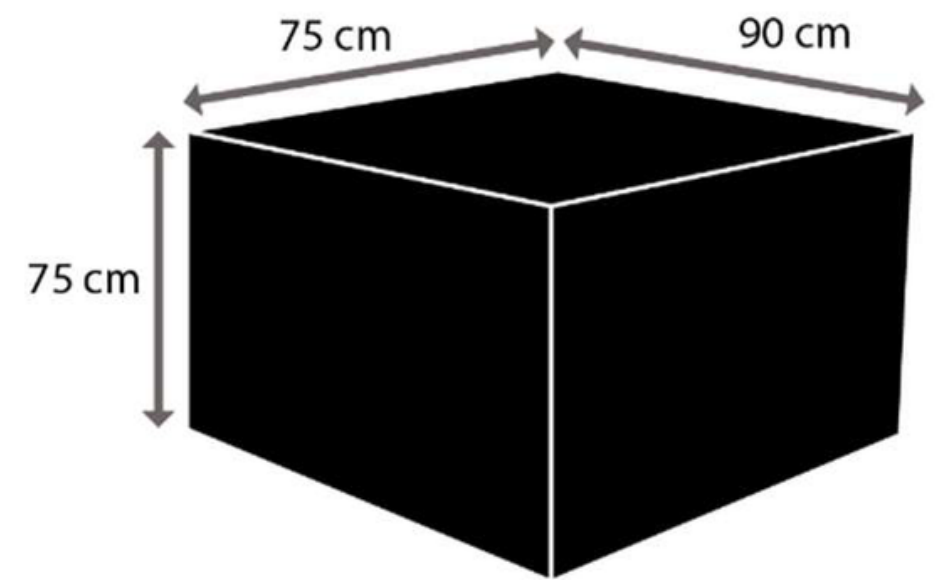

## CLASS 24

### BEAT AROUND THE BUSH

A play on words. When someone can't come to a decision, it is said that they are beating around the bush or going around in circles.

Sponsored by:  
Floral Designers' Club of  
Bunbury, Western Australia

- Staged on continuous bench  
75 cm from the floor
- Bench covered with black fabric
- Space allowed: 90cm wide x  
75 cm deep x height optional
- Viewed and judged from  
both front and sides

**This IMPOSÉ class will be  
staged on 22 March 2027**

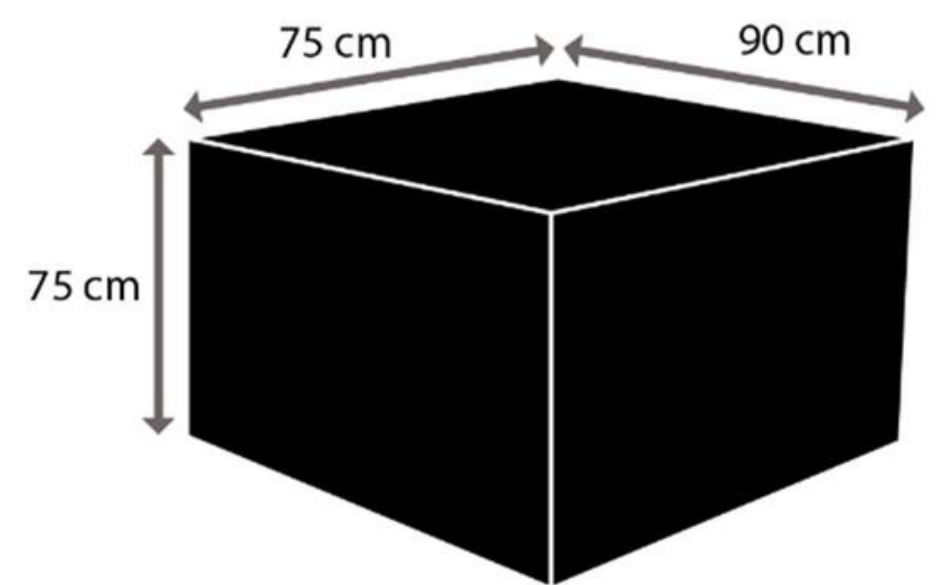

# **SPECIAL AWARDS SPONSORS**

---

## **BEST IN SHOW**

**Sponsored by: Angela Lewis (dec),  
Queensland**

## **BEST IN SHOW RUNNER UP**

**Sponsored by: Alethia Quick OAM,  
South Australia**

## **BEST USE OF COLOUR**

**Sponsored by: Cecily Rogers OAM,  
New South Wales**

## **BEST USE OF FOLIAGE**

**Sponsored by: the Australian Floral  
Art Association**

## **MOST INTERPRETIVE EXHIBIT**

**Sponsored by: Helen Mitchell,  
New South Wales**

## **MOST CREATIVE OR INNOVATIVE EXHIBIT**

**Sponsored by: Arlene Robinson,  
New South Wales**

## **AWARD FOR ARTISTIC EXCELLENCE**

**Sponsored by: Eileen Wenn OAM,  
Western Australia**

## **BEST IMPOSED CLASS**

**Sponsored by: Lanny Pramana,  
New South Wales**

## **BEST USE OF TEXTURE**

**Sponsored by: Mandurah Floral Art  
Group, Western Australia**

## **BEST JUNIOR EXHIBIT**

**Sponsored by: Mandurah Floral Art  
Group, Western Australia**

---

Our stunning awards are from Don Sheil - An iconic Australian maker renowned for handcrafted aluminium homewares that blend artistry with everyday function. Since 1971, the Sheil family has produced distinctive trays, bowls, drinkware, and table accessories, each individually hand-finished and etched with unique patterns inspired by Australian flora, fauna, and cultural motifs. Every piece is crafted in Australia using a proprietary food-safe aluminium alloy, resulting in durable, oven- and freezer-safe designs that are both practical and collectible. Today, the Don Sheil legacy continues through contemporary artisans who uphold the brand's commitment to craftsmanship, originality, and timeless Australian style.



*Don Sheil*™

# WAFA WORLD FLOWER SHOW SPONSORS

A show such as the WAFA Australia World Flower Show doesn't happen without the help and support of generous businesses and individuals.

Our heartfelt thanks go to each of these businesses, clubs and individuals:



Royal Agricultural Society of NSW



<https://premiumgreensaustralia.com>



**Canberra Flower Club Inc.**

*Friendship thru Flowers*

*Affiliated with AFSA Australian Floral Art Association*



The Floral Art Society of Queensland Inc.



- Millicent & District Floral Art Club
- Contemporary Floral Design Group Mid North Coast
- Woodville Academy of Floral Design
- Unley Floral Design Club
- Blackwood Floral Art Group
- Contemporary Floral Design Group Sydney



- Angela Lewis (dec)
- Arlene Robinson
- Helen Mitchell
- Alethia Quick OAM
- Cecily Rogers OAM
- Eileen Wenn OAM
- Lanny Pramana
- David & Sharryn Place
- Jean Shine

We are delighted to host this vibrant celebration of floral art, bringing together passionate designers and enthusiasts from around the globe. As we gather to share creativity, culture, and friendship through flowers, may this event inspire awe, connection, and lasting memories. Let the beauty of blooms unite us all.

